



**COMPLEMENTI**

*Occasionals  
Beimöbel  
Accessories  
Complementos*

**PARETI  
ATTREZZATE**

*Wall system  
Wandprogramm  
Paroi composables  
Paredes equipadas*

**MOBILI**

*Furnishings  
Einrichtung  
Mobilier  
Muebles*



**Dovrò  
eliminare  
qualcosa**

*I will have  
to eliminate  
something*



Mito  
vol. / 01 \_ 88



## OK-4

Design \_ Domitalia

Patented

**ZONA GIORNO \_ LIVING**

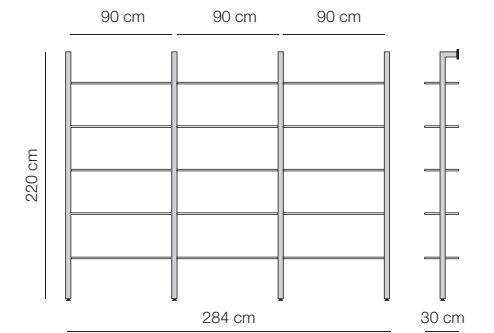

Universe-160  
90 x 160 (+50+50) cm

Xtra-140  
80 x 140 cm

vol. / 02 \_100

vol. / 02 \_184



### Packing

Kg. 121,6 \_ m²0,16 \_ 11 boxes (ripiani vetro \_ glass shelves)

Kg. 74,5 \_ m²0,18 \_ 11 boxes (ripiani legno \_ wooden shelves)

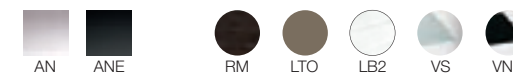

# OK-7

Design \_ Domitalia

Patented

ZONA GIORNO \_ LIVING

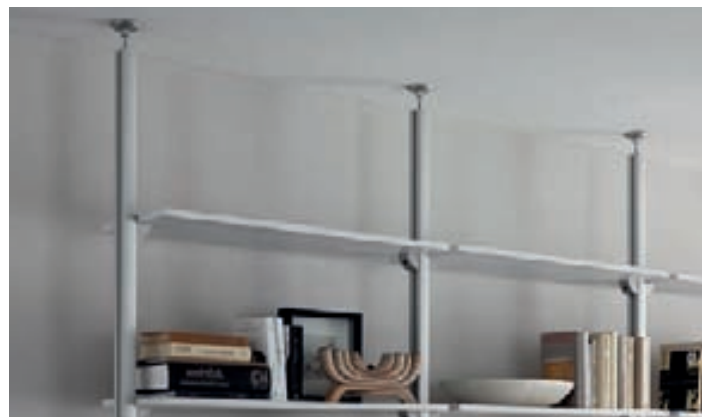
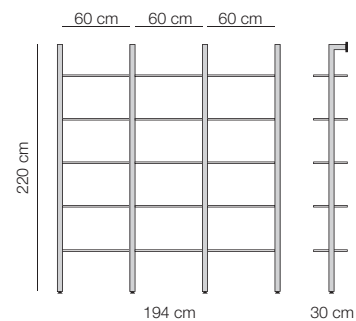

Cloud-A



vol. / 01\_90



## Packing

Kg. 87,1 \_ m³0,13 \_ 11 boxes (ripiani vetro \_ glass shelves)

Kg. 54,9 \_ m³0,14 \_ 11 boxes (ripiani legno \_ wooden shelves)





# OK-8

Design \_ Domitalia  
Patented

**ZONA GIORNO \_ LIVING**

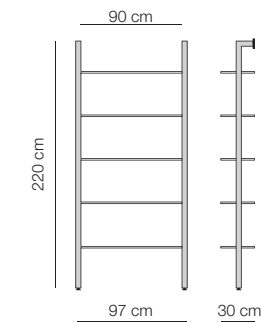

**Packing**

Kg. 42,6 \_ m³0,06 \_ 4 boxes (**ripiani vetro** \_ glass shelves)  
Kg. 27 \_ m³0,06 \_ 4 boxes (**ripiani legno** \_ wooden shelves)

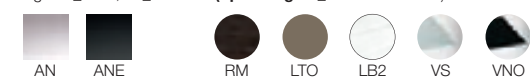

# OK-9

Design \_ Domitalia

Patented

ZONA GIORNO \_ LIVING

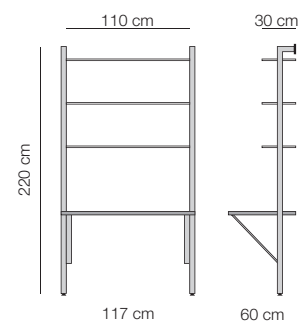

Gel-D



vol. / 01 \_ 122



### Packing

Kg. 44 \_ m³0,08 \_ 5 boxes

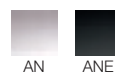

Finiture ripiani  
Finish of shelves

Finiture scrittoio  
Finish of desk



Coquille-T  
vol. / 01 \_ 16

**38 gradi  
all'ombra**

*38  
degrees  
in the shade*



# OK-12

Design \_ Domitalia  
Patented

ZONA GIORNO \_ LIVING

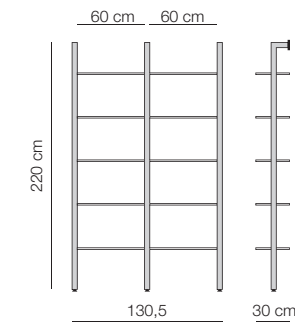

**Packing**  
Kg. 59 \_ m<sup>3</sup> 0,08 \_ 7 boxes (ripiani vetro \_ glass shelves)  
Kg. 37,5 \_ m<sup>3</sup> 0,08 \_ 7 boxes (ripiani legno \_ wooden shelves)

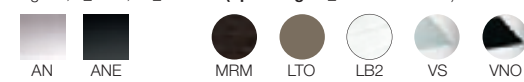

# OK-NE

Design \_ Domitalia

Patented

ZONA NOTTE \_ WALK-IN CLOSET

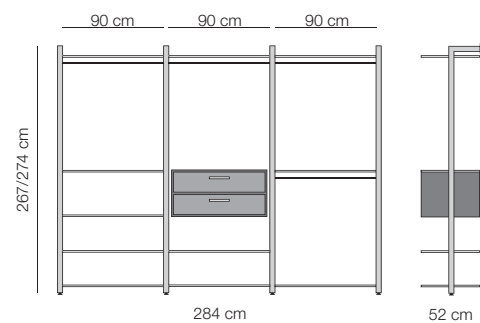

**Packing**  
Kg. 132 \_ m<sup>3</sup> 0,59 \_ 19 boxes



Ripiani e cassetti in melaminico  
Melamine tops and drawers

# OK-NB

Design \_ Domitalia

Patented

ZONA NOTTE \_ WALK-IN CLOSET

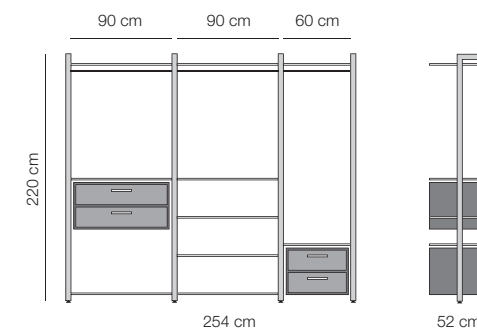

**Packing**  
Kg. 131 \_ m<sup>3</sup> 0,68 \_ 16 boxes



Ripiani e cassetti in melaminico  
Melamine tops and drawers

# OK-NC

Design \_ Domitalia  
Patented

ZONA NOTTE \_ WALK-IN CLOSET

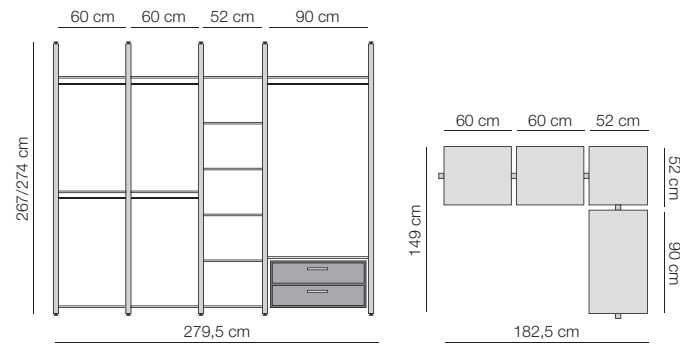

**Packing**  
Kg. 120 \_ m<sup>3</sup> 0,57 \_ 23 boxes



Ripiani e cassetti in melaminico  
Melamine tops and drawers

# OK-ND

Design \_ Domitalia  
Patented

ZONA NOTTE \_ WALK-IN CLOSET

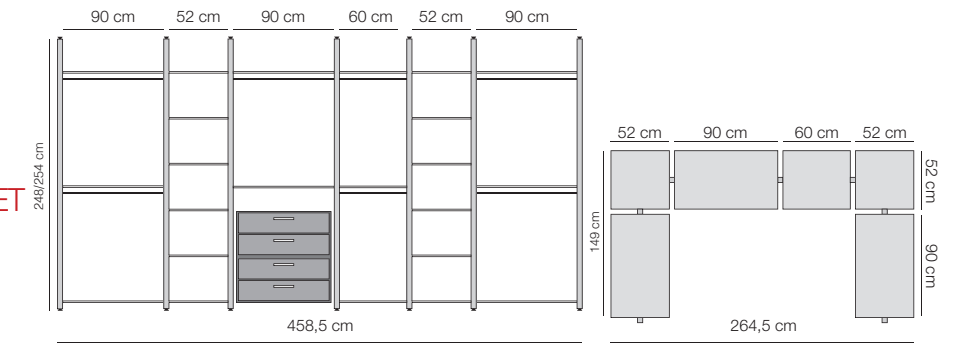

**Packing**  
Kg. 219 \_ m<sup>3</sup> 1,03 \_ 38 boxes



Ripiani e cassetti in melaminico  
Melamine tops and drawers





# CONTOUR-125

Design \_ Paul Stott  
Patented



Sierra



vol. / 01 \_ 78



**Packing**

Kg. 83,4 \_ m³ 0,66 \_ 1 x box / 5 boxes



Struttura \_ Body

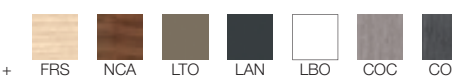

Zoccolo \_ Plinth

Anta centrale \_ Central door



Piani \_ Tops

# CONTOUR-185

Design \_ Paul Stott  
Patented



Opera



vol. / 01 \_ 74

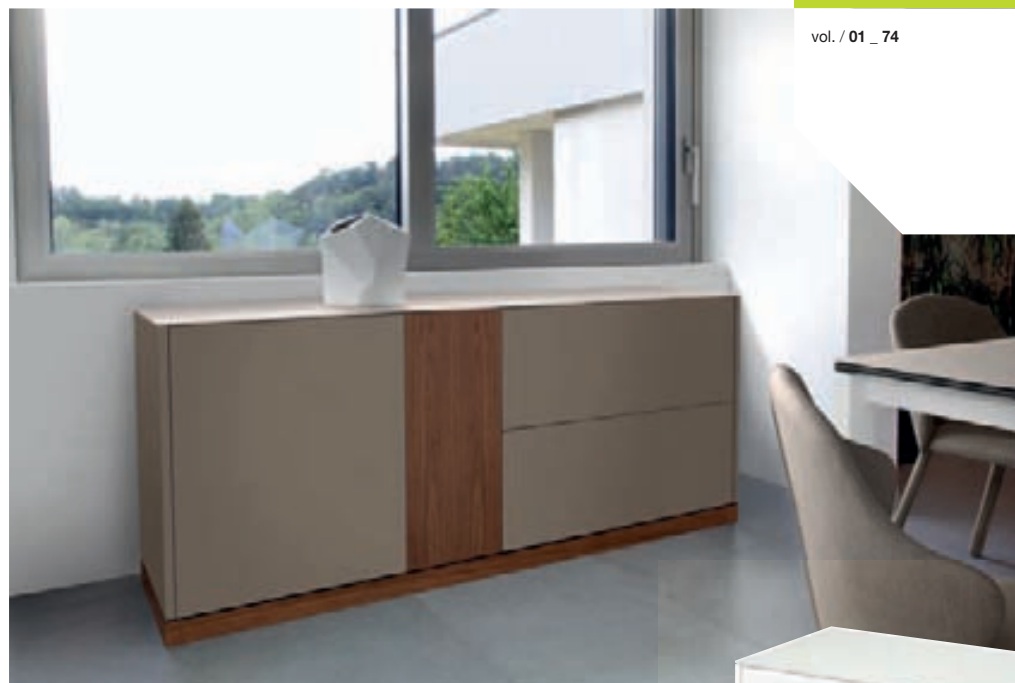

**Packing**  
Kg. 120 \_ m<sup>3</sup> 0,98 \_ 1 x box / 5 boxes



Struttura \_ Body



Zoccolo \_ Plinth

Anta centrale \_ Central door



Piani \_ Tops



Flexa-LX  
vol. / 01 \_ 156



Urban-LO  
vol. / 02 \_ 152



**Voglio lasciare il segno**

*I want to leave a mark*



# CONTOUR-TV



Design \_ Paul Stott  
Patented

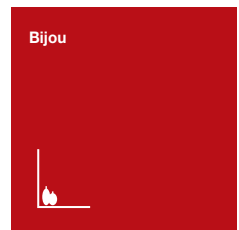

vol. / 02 \_ 172



**Packing**  
Kg. 83,4 \_ m³ 0,61 \_ 1 x box / 5 boxes

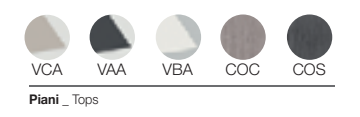
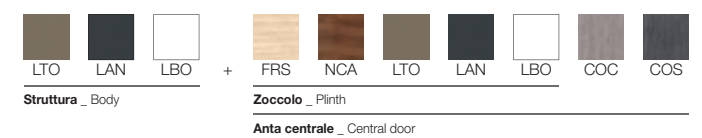

# CONTOUR-V

Design \_ Paul Stott  
Patented



Sono centinaia  
le possibili varianti  
della collezione  
di madie Contour:  
una versatilità  
incredibile che  
nasce proprio  
dall'estrema  
essenzialità  
di questi mobili,  
concepiti  
per permettere  
i più diversi  
abbinamenti.

There are hundreds  
of possible versions  
of the Contour  
sideboards: incredible  
versatility which  
in point of fact comes  
from the extreme  
essentiality of these  
pieces of furniture,  
conceived for the most  
varied combinations.



**Packing**  
Kg. 153 \_ m³ 1,22 \_ 1 x box / 6 boxes



Struttura \_ Body



Zoccolo \_ Plinth

Anta centrale \_ Central door



Piani \_ Tops



 Opera

 Galaxy-160  
95 x 160 (+50+50) cm

 Urban-LG

vol. / 01 \_ 74

vol. / 02 \_ 24

vol. / 02 \_ 156





# BASS-L

Design \_ Domitalia  
Patented

 Mito  
 Must  
 95 x 160 (+90) cm



vol. / 01 \_ 88  
 vol. / 02 \_ 94



**Packing**  
 Kg. 127 \_ m³ 1,15 \_ 1 x box / 2 boxes



# BASS

Design \_ Domitalia  
Patented

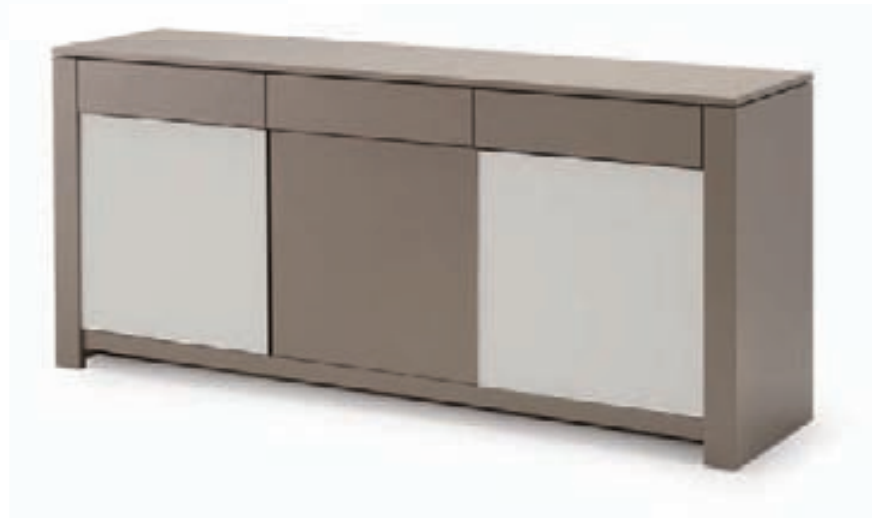

**Packing**  
Kg. 127 \_ m<sup>3</sup> 1,13 \_ 1 x box / 2 boxes



Cliff  
vol. / 01 \_ 80

Discovery  
90 x 160 (+45+45) cm  
vol. / 02 \_ 18

**Viva  
i bassi!**

*Up  
with basses!*



Turn off  
the city,  
there is  
**Urban.**



DOMITALIA





Elegante lampada  
a piantana  
per uso interno  
con struttura  
in metallo  
cromato, piano  
d'appoggio  
in plexiglass  
opalino e calotta  
illuminante  
in polietilene  
traslucido.

*An elegant floor lamp  
for the indoors with  
a chromed metal  
frame, opal plexiglass  
shelf and translucent  
polyethylene  
lightshade.*

## GHOST

Design \_ Radice & Orlandini  
Patented



**Packing**  
Kg. 9,6 \_ m³ 0,40 \_ 1 x box



Ripiano opzionale  
Optional shelf

# URBAN-LO

Design \_ Radice & Orlandini  
Patented



vol. / 01 \_26



Globe

vol. / 02 \_60



Corona-120  
ø119 cm



**Packing**  
Kg. 35,7 \_ m³ 0,28 \_ 1 x box / 3 boxes

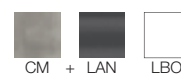

Gea  
vol. / 01 \_ 148



Universe-160  
90 x 160 (+50+50+50) cm  
vol. / 02 \_ 100



Voglia  
di New York

Feel like  
New York



Oggi  
lucido  
l'argenteria



Jude-L  
vol. / 01 \_ 162



Web-140  
90 x 140 (+45+45) cm  
vol. / 02 \_ 106

Today,  
I polish  
the silverware



## URBAN-LS

Design \_ Radice & Orlandini  
Patented



Traffic-T



Archie-240  
110 x 240 cm

vol. / 01 \_ 98

vol. / 02 \_ 52

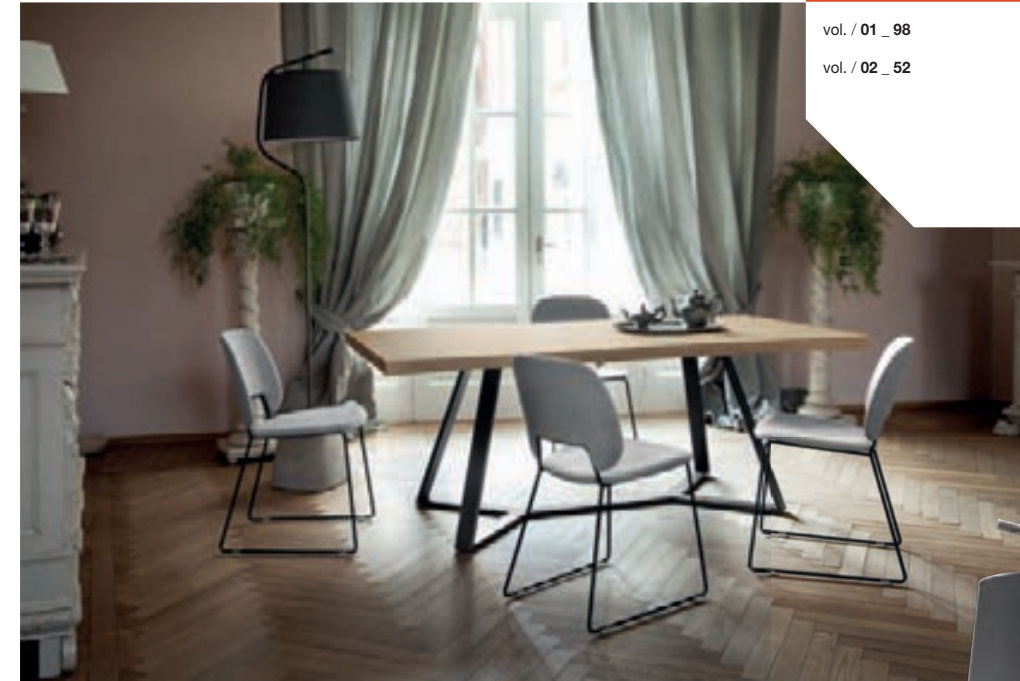

### Packing

Kg. 37 \_ m³ 0,31 \_ 1 x box / 3 boxes



45

45

172



CM

+

LAN

LBO

# URBAN-LG

Design \_ Radice & Orlandini  
Patented

 Torque  
vol. / 01 \_ 152

 Maxim-182  
98 x 182 (+50+50) cm  
vol. / 02 \_ 90

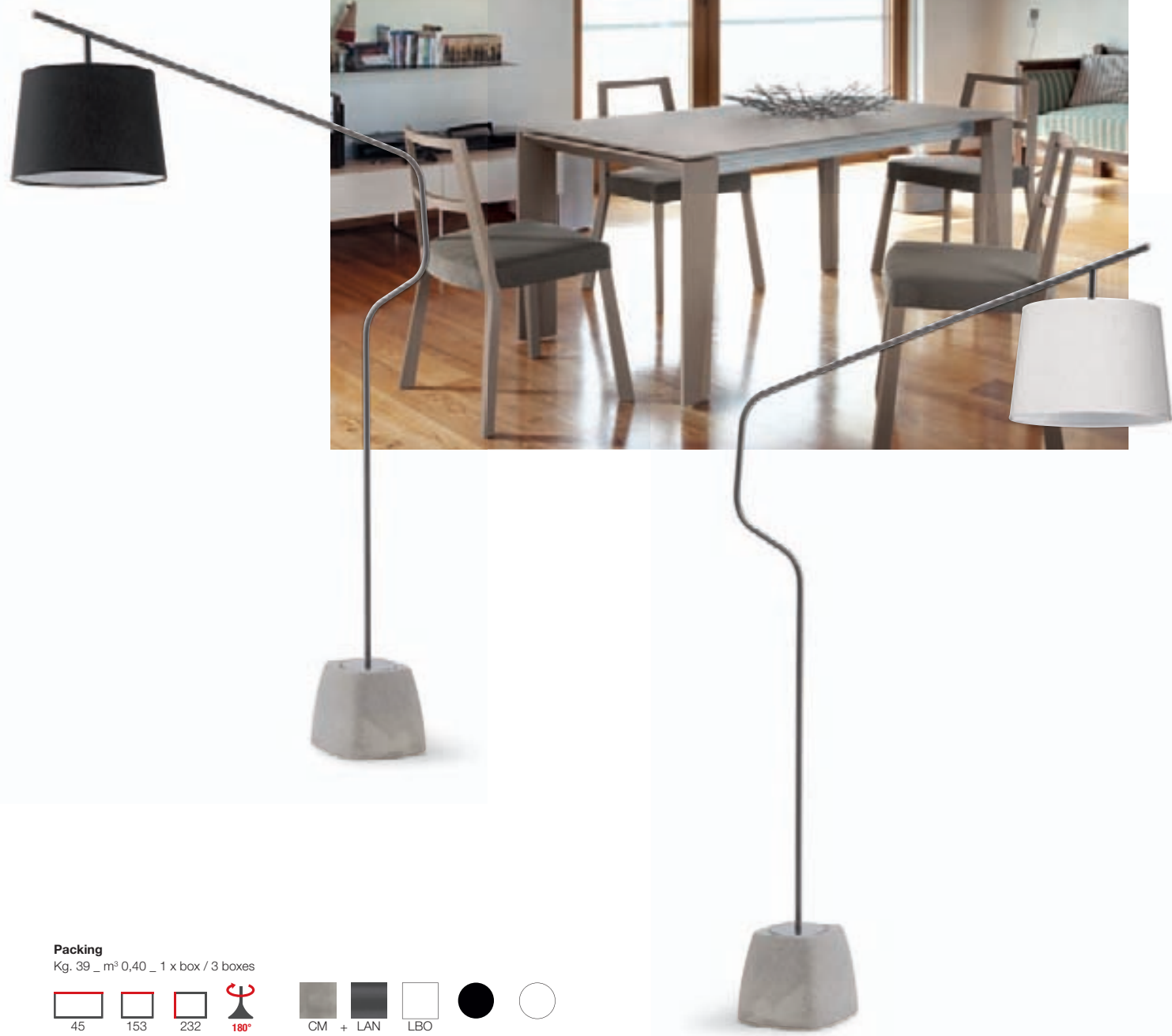
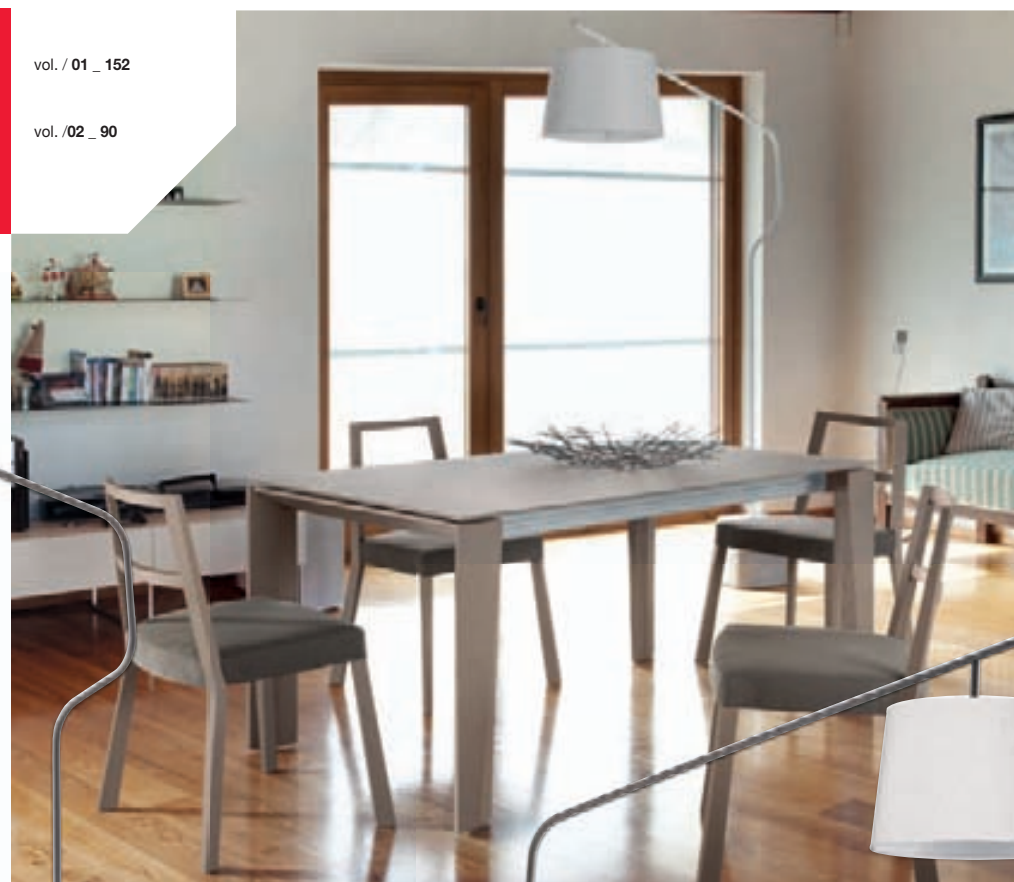

**Packing**  
Kg. 39 \_ m³ 0,40 \_ 1 x box / 3 boxes

  
45 153 232 180°  
CM + LAN LBO



Contour-185  
185 x 49 H80 cm  
vol. / 02 \_ 136

Uno strappo alla regola  
*An exception to the rules*

Oggi  
ho preso  
una multa

Today  
I got  
a ticket



Traffic  
vol. / 01 \_ 94



## URBAN-A

Design \_ Radice & Orlandini  
Patented



Packing  
Kg. 38,5 \_ m³ 0,20 \_ 1 x box / 2 boxes



# URBAN-B

Design \_ Radice & Orlandini  
Patented

Anais  
Discovery  
98 x 160 (+45+45) cm

vol. / 01 \_ 118  
vol. / 02 \_ 18

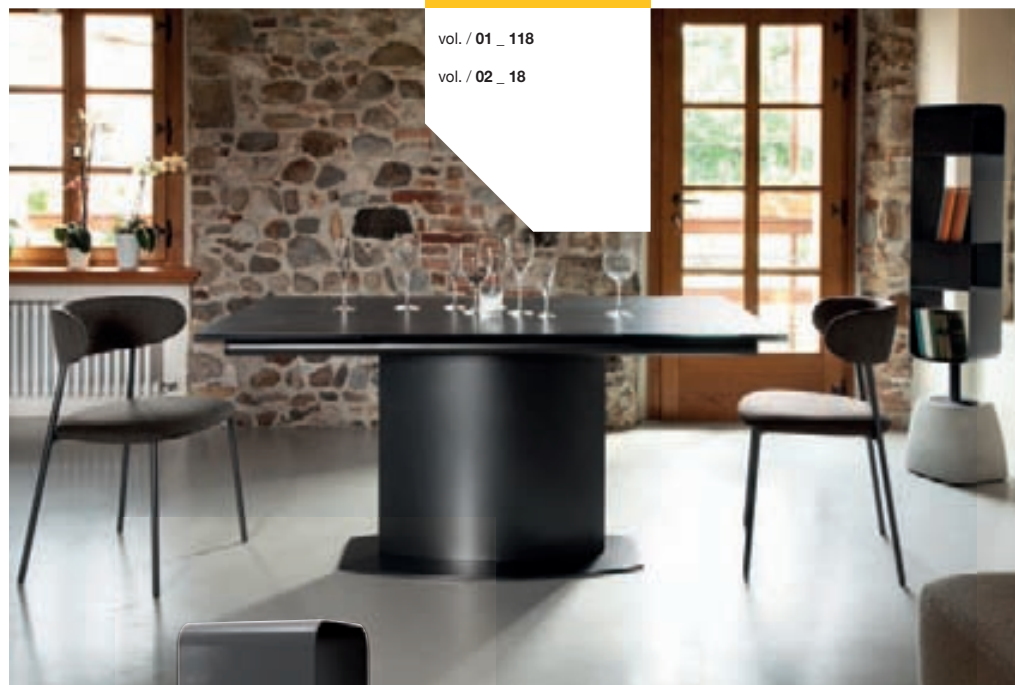

Traffic-T  
vol. / 01 \_ 98

Cosa facciamo dopo?  
Where are we going next?

Packing  
Kg. 48 \_ m³ 0,14 \_ 1 x box / 2 boxes

32 32 152 360° CM + LSE LAM LAN LBO



# URBAN-CG

Design \_ Radice & Orlandini  
Patented

Urban-B

vol. / 02 \_ 160

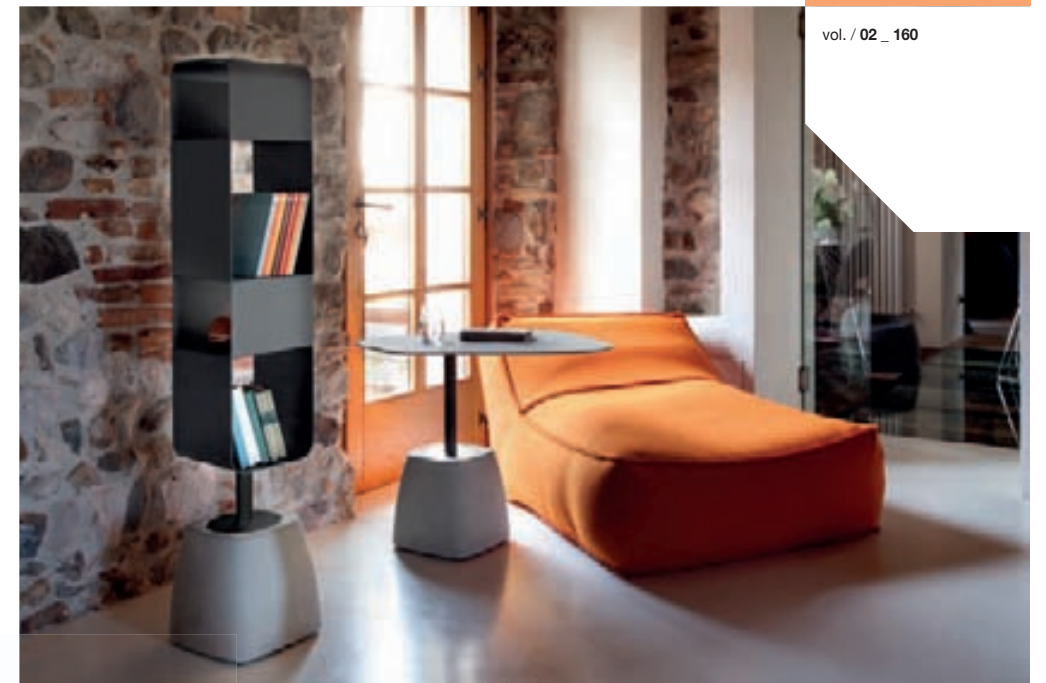

**Packing**  
Kg. 41,6 \_ m³ 0,10 \_ 1 x box / 3 boxes



CM + LAN LBO NTMN NTMB

Piano laminato Nano Tech Matt  
Nano Tech Matt laminate top



**Il calcestruzzo è un materiale con un suo fascino grezzo, architettonico, metropolitano. Da materiale strutturale, con Urban si trasforma in un elemento decorativo per rivoluzionare la qualità e l'estetica della vita in casa: dal tavolino, alle lampade, agli accessori.**

*Concrete is a material, which has an untreated, architectural, metropolitan fascination. Changing its role from being a structural material, with Urban it has become a decorative element to revolutionize the quality and aesthetics of life at home: from the coffee table, to lamps, to accessories.*



## SCULTURA D'ARREDO

È un'opera d'arte contemporanea oppure un appendiabiti? Questo elemento della collezione Urban veste entrambe le personalità, in tutte le stagioni.



*A sculptured work of art or a piece of furniture? Is it a contemporary artwork or a coat rack? This element of the Urban collection can take on both features, throughout all seasons.*



\_ 158

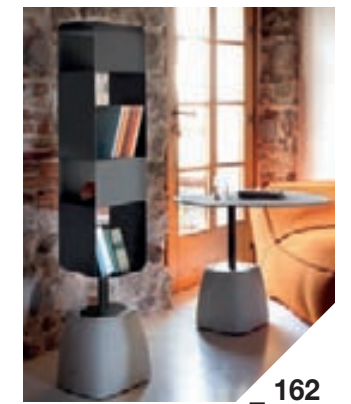

\_ 162

## IDEE COSTRUTTIVE

Un nuovo modo di fare salotto: il tavolino girevole Urban, con piano in una resina prodotta grazie all'uso di nanotecnologie, ha una morbida superficie anti impronte e permette di rigenerare termicamente eventuali micrograffi.

### Constructive ideas

*A new way for you to spend time in the living room: the swivel Urban coffee table with a resin top manufactured thanks to the implementation of nanotechnologies. It has a soft fingerprint-proof surface and it thermally regenerates any small scratches.*

## PROGETTI ILLUMINANTI

Le lampade Urban si presentano in tre varianti e mettono in nuova luce la natura e le possibilità del calcestruzzo come materiale di design.

*Enlightening projects*  
Urban lamps are in three versions and highlight the nature and possibilities of concrete as design material.



\_ 160

## CULTURA DEL PROGETTO

La libreria girevole Urban è destinata a non passare inosservata: un'idea utile anche per ottimizzare lo spazio sfruttando la possibilità di essere collocata ovunque, grazie alla sua caratteristica di essere autoportante.

### Project culture

*The fate of the swivel Urban bookcase is not to go by unnoticed: a useful idea to optimize room by exploiting the possibility of being placed anywhere, as it is freestanding.*



\_ 152



\_ 156



# CROSS

Design \_ Radice & Orlandini  
Patented



CROSS-QB

CROSS-QA

CROSS-R

## Packing

CROSS-QA \_ Kg. 7 \_ m<sup>3</sup> 0,13 \_ 1 x box / 2 boxes  
CROSS-QB \_ Kg. 6,5 \_ m<sup>3</sup> 0,11 \_ 1 x box / 2 boxes  
CROSS-R \_ Kg. 16 \_ m<sup>3</sup> 0,22 \_ 1 x box / 2 boxes

50	50	60
50	50	50
110	70	40

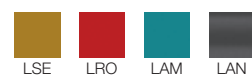

Piano in HPL  
HPL top





# SUSHI-C

Design \_ Domitalia  
Patented



vol. / 02 \_ 170

Sushi-L  
60 x 60 H32 cm



**Packing**  
Kg. 24 \_ m³ 0,11 \_ 1 x box / 2 boxes

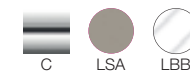
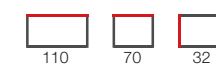

Piano in MDF  
MDF top

# SUSHI-L

Design \_ Domitalia  
Patented

Sushi-C  
70 x 110 H32 cm



vol. / 02\_168



**Packing**  
Kg. 13 \_ m³ 0,08 \_ 1 x box / 2 boxes

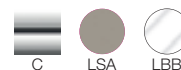
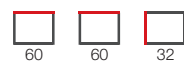

Piano in MDF  
MDF top

Sushi-C  
70 x 110 H32 cm  
vol. / 02\_168

Urban-LG  
vol. / 02\_156

Voglia  
di sushi

Feel like  
sushi



Ore 8:15  
tagliando

Contour-TV  
160 x 49 H44 cm  
vol. / 02 \_ 138

8:15 am,  
car  
service



## BIJOU

Design \_ Edi & Paolo Ciani  
Patented



**Packing**  
Kg. 17,2 \_ m³ 0,30 \_ 1 x box / 2 boxes

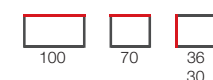

# TOSCA

Design \_ Adriano Balutto Associati  
Patented



TOSCA-Q



TOSCA-C

TOSCA-Q  
Packing  
Kg. 19 \_ m³ 0,06 \_ 1 x box

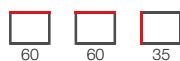

TOSCA-C  
Packing  
Kg. 30,2 \_ m³ 0,10 \_ 1 x box

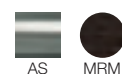
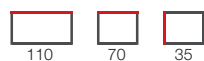

Piano in tamburato  
Honeycomb top





# ROY-M

Design \_ Gerald Brandstätter  
Patented



**Packing**  
Kg. 37 \_ m³ 0,25 \_ 1 x box / 2 boxes



MNCA LBB

Piano melaminico  
Melamine top

# NEXT-10

Design \_ Domitalia  
Patented



**Packing**  
Kg. 25 \_ m³ 0,14 \_ 1 x box

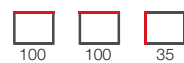

**Piano impiallacciato**  
Veneered top



Traffic-T  
vol. / 01 \_ 98



La prossima  
volta  
segno io!

Next time  
I will score  
a goal!



# GAME

Design \_ Adriano Balutto Associati  
Patented

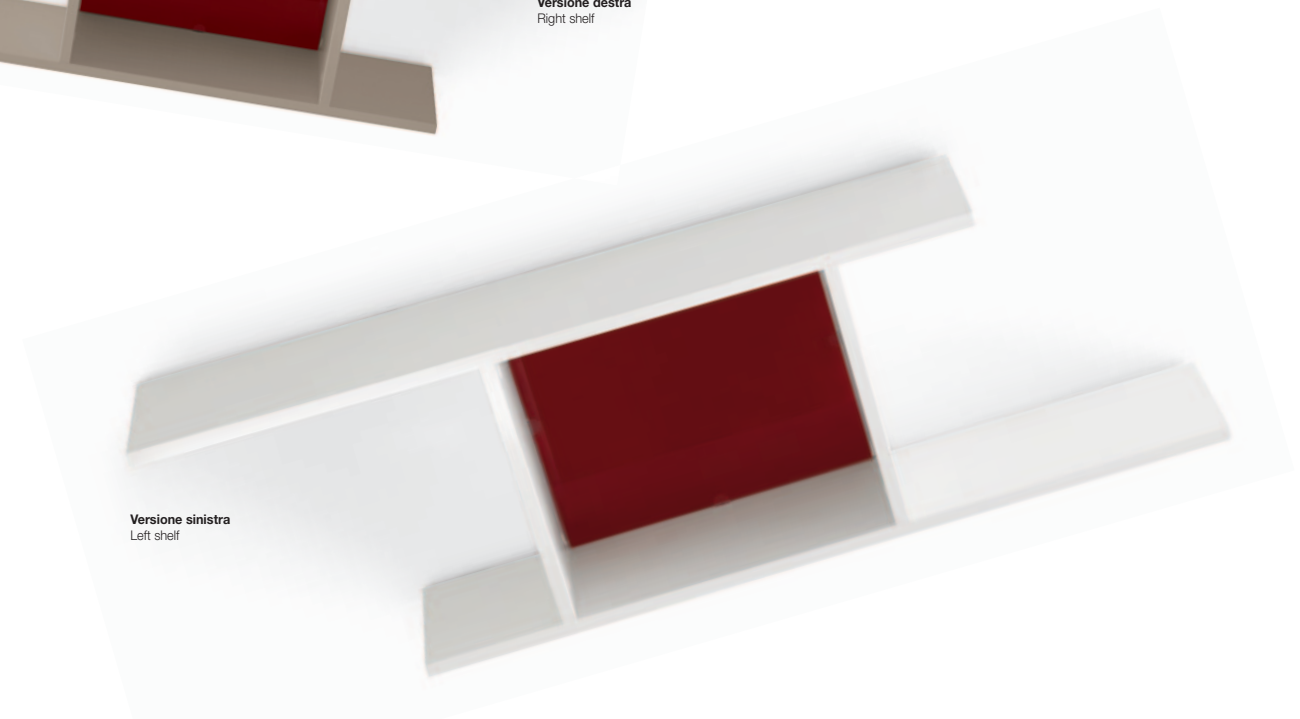
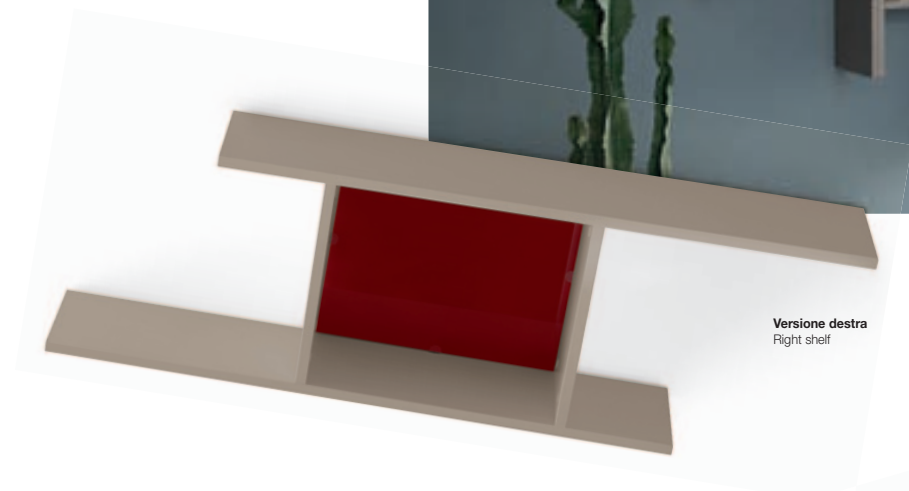

**Packing**  
Kg. 11 \_ m<sup>2</sup> 0,03 \_ 1 x box



**Inserto in vetro opzionale**  
Optional glass back



# HANDY

Design \_ Area 44

Patented



#### Packing

Kg. 1 \_ m<sup>3</sup> 0,07 \_ 1 x box



49

36

35



RTO

RNE

RBI

Deriva da “hand”  
(mano) il nome  
del praticissimo  
portariviste Handy  
che, grazie  
alla maniglia sul  
lato superiore, può  
essere trasportato  
agevolmente.

La struttura  
in pelle forma due  
tasche laterali  
nelle quali riporre  
riviste e quotidiani.  
Un complemento  
d’arredo dal  
design originale  
disponibile  
nei colori tortora,  
bianco o nero.

*Handy has a name*  
*deriving from the*  
*word “hand” – it*  
*is a very practical*  
*magazine rack which*  
*can be conveniently*  
*moved thanks to the*  
*handles on the top.*  
*Its leather structure*  
*has two side pockets*  
*for magazines and*  
*newspapers. An*  
*accessory with an*  
*original design*  
*available in taupe,*  
*white or black.*



## XTRA-140

Design \_ Domitalia  
Patented

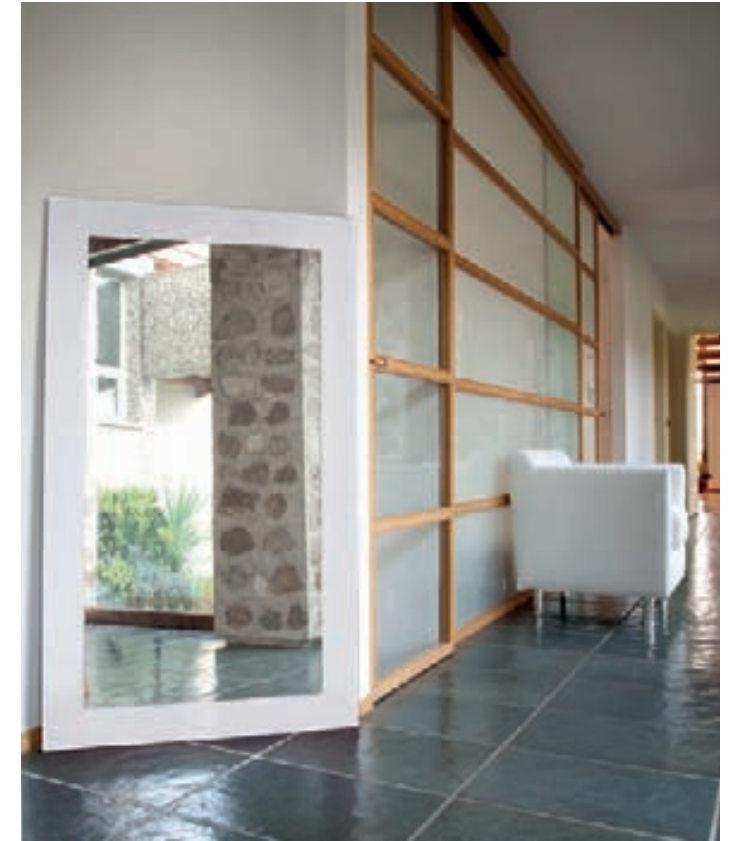

**Packing**  
Kg. 23 \_ m<sup>2</sup> 0,05 \_ 1 x box



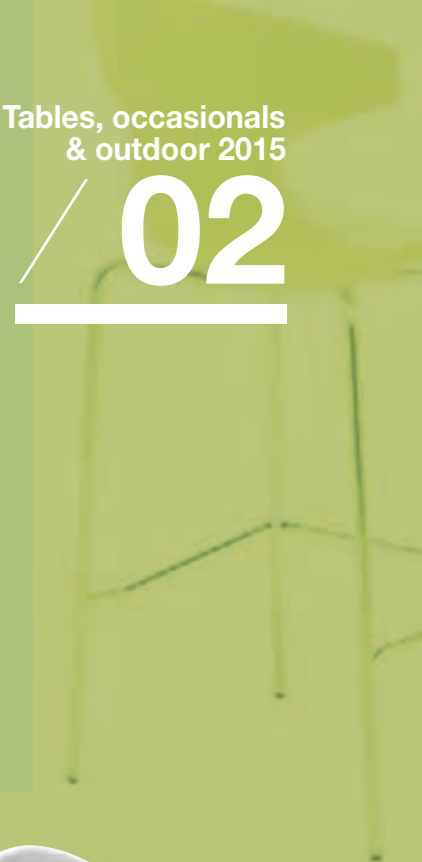

**SEDIE  
OUTDOOR**

*Chairs for outdoor  
Stühle für Outdoor  
Chaises outdoor  
Sillas de outdoor*



M'ama...  
non m'ama...

He  
loves me,  
he loves  
me not...



Compass  
70 x 70 cm  
vol. / 02 \_ 228

# STONE-P

Design \_ Arter & Citton  
Patented

Stone-R200  
104 x 200 cm



vol. / 02 \_ 222



### Packing

Kg. 13 \_ m³0,29 \_ 1 x box

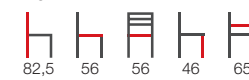

# PHANTOM

Design \_ Radice & Orlandini

Patented



## Packing

Kg. 11,6 \_ m³0,38 \_ 1 x box

Kg. 1,3 \_ m³0,01 \_ 1 x box (Kit con filo \_ Kit with cord)

Kg. 1,5 \_ m³0,01 \_ 1 x box (Kit con filo e lampadina led \_ Kit with cord and led bulb)

Kg. 3 \_ m³0,01 \_ 1 x box (Kit senza filo \_ Kit without cord)



Compass  
70 x 70 cm  
vol. / 02 \_ 228

**Franz  
o Stones?**

*Franz  
or Stones?*





Poltrona realizzata  
in polietilene  
100% riciclabile.  
La forma ricrea  
un elegante  
drappeggio  
d'ispirazione  
classica. Facile  
da pulire,  
resistente  
alle abrasioni  
e agli agenti  
atmosferici.

*An armchair  
in 100% recyclable  
polyethylene.  
Its shape re-creates  
drapery of classical  
inspiration.  
Easy to clean,  
scratch-proof  
and weatherproof.*

Disco mania

Disco mania

Phantom  
vol. / 02 \_ 190

Casper  
vol. / 02 \_ 196

# PHANTOM2

Design \_ Radice & Orlandini  
Patented

Phantom

Casper

vol. / 02 \_ 190

vol. / 02 \_ 196



### Packing

Kg. 25 \_ m³0,81 \_ 1 x box

Kg. 2,6 \_ m³0,02 \_ 1 x box / 2 boxes (Kit con filo \_ Kit with cord)

Kg. 3 \_ m³0,02 \_ 1 x box / 2 boxes (Kit con filo e lampadina led \_ Kit with cord and led bulb)

Kg. 6 \_ m³0,02 \_ 1 x box / 2 boxes (Kit senza filo \_ Kit without cord)

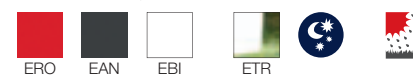

# CASPER

Design \_ Radice & Orlandini  
Patented

Phantom2



vol. / 02 \_ 194



**Packing**

Kg. 4,5 \_ m²0,09 \_ 1 x box

Kg. 1,3 \_ m²0,01 \_ 1 x box (**Kit con filo** \_ Kit with cord)

Kg. 1,5 \_ m²0,01 \_ 1 x box (**Kit con filo e lampadina led** \_ Kit with cord and led bulb)

Kg. 3 \_ m²0,01 \_ 1 x box (**Kit senza filo** \_ Kit without cord)

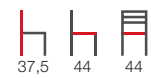





Ore 11.00  
beach  
volley  
11am,  
beach volley

Omnia  
vol. / 02 \_ 240



# BABÀ

Design \_ Radice & Orlandini  
Patented

Omnia



vol. / 02 \_ 240

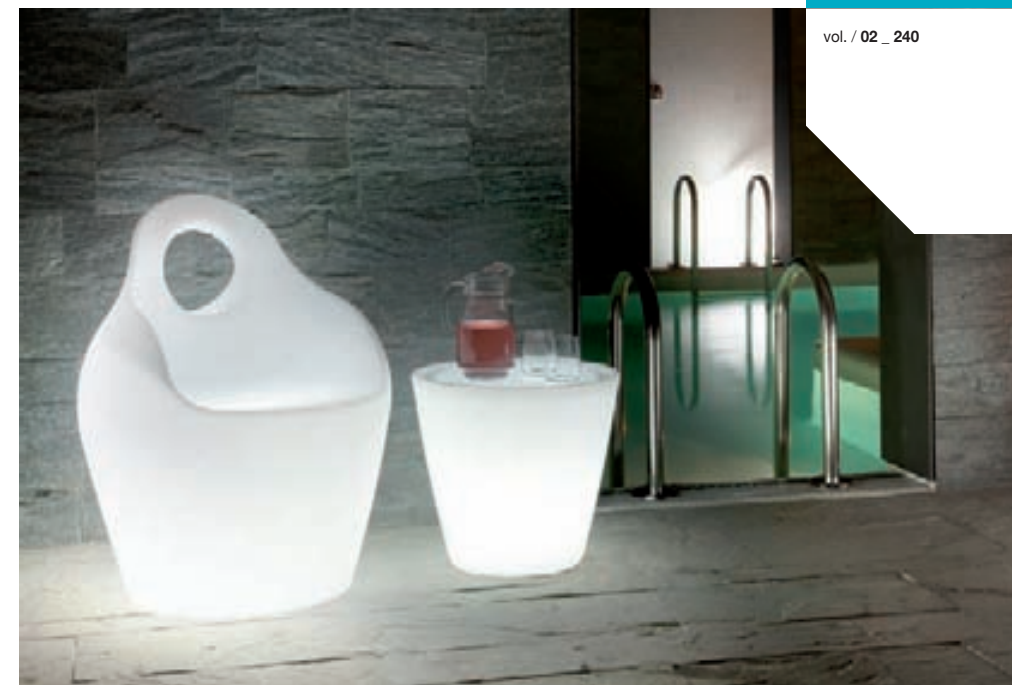

### Packing

Kg. 10 \_ m³0,42 \_ 1 x box

Kg. 1,3 \_ m³0,01 \_ 1 x box (Kit con filo \_ Kit with cord)

Kg. 1,5 \_ m³0,01 \_ 1 x box (Kit con filo e lampadina led \_ Kit with cord and led bulb)

Kg. 3 \_ m³0,01 \_ 1 x box (Kit senza filo \_ Kit without cord)

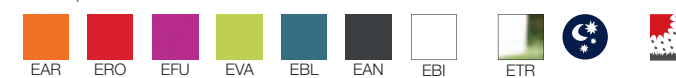

# BABÀ-JR

Design \_ Radice & Orlandini  
Patented



## Packing

Kg. 5 \_ m³0,18 \_ 1 x box

Kg. 1,3 \_ m³0,01 \_ 1 x box (**Kit con filo** \_ Kit with cord)

Kg. 1,5 \_ m³0,01 \_ 1 x box (**Kit con filo e lampadina led** \_ Kit with cord and led bulb)

Kg. 3 \_ m³0,01 \_ 1 x box (**Kit senza filo** \_ Kit without cord)



Relax  
in piscina

Relax  
at the pool

Omnia  
vol. / 02 \_ 240

**Babà-jr**  
**è la poltrona**  
**da esterno**  
**dedicata ai più**  
**piccoli. Le forme**  
**tondeggianti**  
**di Babà sono state**  
**ridotte e riadattate**  
**mantenendo**  
**il comfort**  
**e il caratteristico**  
**design**  
**avvolgente.**

*Babà Jr. is*  
*an outdoor armchair*  
*for kids. Its rounded*  
*outline has been*  
*trimmed down*  
*and adjusted,*  
*keeping its comfort*  
*and characteristic*  
*embracing design*  
*unchanged.*





# FORYOU

Design \_ *Edi & Paolo Ciani*  
Patented

Compass  
ø 70 cm



vol. / 02 \_ 228



**Packing**  
Kg. 16,8 \_ m³ 0,35 \_ 4 x box



# FORYOU2

Design \_ Edi & Paolo Ciani  
Patented



**NON DISPONIBILE**  
**NOT AVAILABLE**



Packing  
Kg. 16,8 \_ m³ 0,35 \_ 4 x box



**NON DISPONIBILE**  
**NOT AVAILABLE**

Visita  
di controllo

Check-up



Crown  
ø70 cm  
vol. / 02 \_ 232



## ECHO

Design \_ Arter & Citton  
Patented



Packing  
Kg. 11,2 \_ m³0,24 \_ 2 x box / 2 boxes



# ECHO-SGB

Design \_ Arter & Citton  
Patented



Packing  
Kg. 10 \_ m³0,23 \_ 1 x box / 2 boxes





# NEW RETRÒ

Design \_ Fabrizio Batoni  
Patented

Compass  
70 x 70 cm



vol. / 02 \_ 228



Packing  
Kg. 16,8 \_ m³ 0,35 \_ 4 x box





Colazione  
in giardino?

Breakfast  
in the garden?

Babà  
vol. / 02\_198

Babà-jr  
vol. / 02\_200

Stone-R240  
104 x 240 cm  
vol. / 02\_222

Alta tecnologia e applicazione di materiali innovativi per un modello che nelle linee come nella compattezza e solidità ricorda la struttura di una sedia in legno. New Retrò è 100% riciclabile ed è adatta sia per l'uso interno che per l'outdoor.

High technology and use of innovative materials for a model whose outline, compactness and sturdiness evoke the structure of a wooden chair. New Retrò is 100% recyclable and is suitable for the indoors and outdoors.

# CRYSTAL

Design \_ Arter & Citton  
Patented



**Packing**  
Kg. 20 \_ m<sup>3</sup>0,43 \_ 4 x box  
86 56 49 46 max 6



TAVOLI  
OUTDOOR

*Tables for outdoor  
Tische für Outdoor  
Tables outdoor  
Mesas de outdoor*

Ora voglio  
investigare...

Now,  
I want  
to  
investigate...



Foryou  
vol. / 02 \_ 204

# MIRAGE

Design \_ Domitalia  
Patented

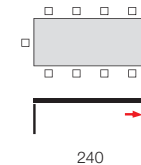

Foryou



vol. / 02 \_ 204

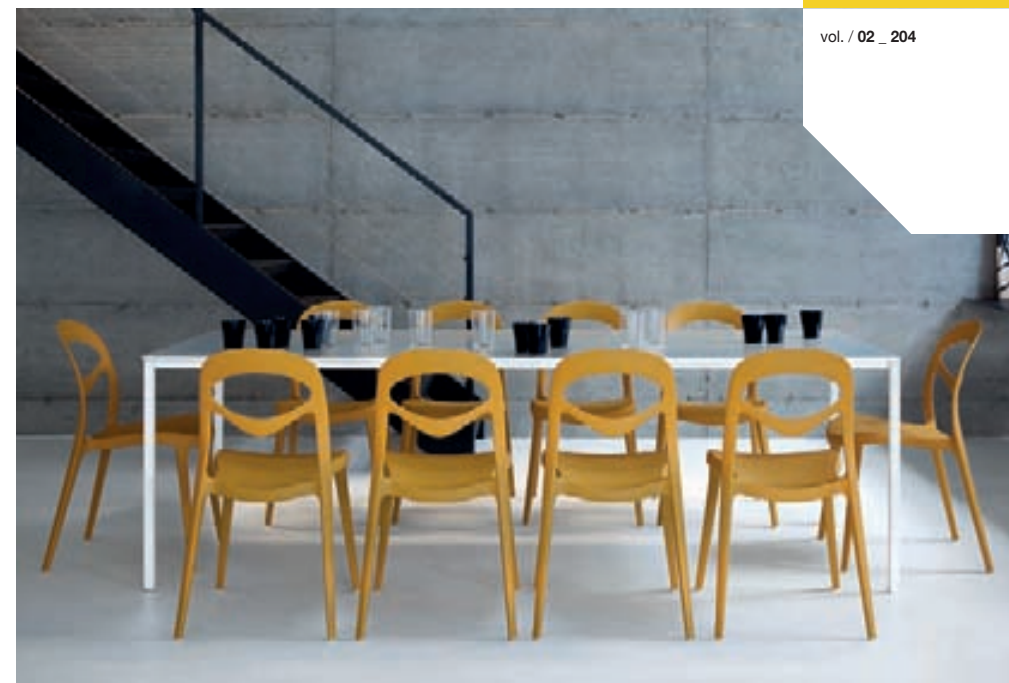

### Packing

Kg. 36 \_ m<sup>3</sup>0,30 \_ 1 x box / 3 boxes



Piano in alluminio alveolare anodizzato  
Alveolar anodized aluminium top

# STONE-R

Design \_ Arter & Citton

Patented

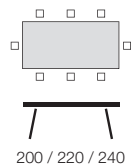

vol. / 02 \_ 188



Stone-P

vol. / 02 \_ 240



Omnia



## Packing

200 cm: Kg. 50 \_ m<sup>3</sup>0,22 \_ 1 x box / 3 boxes

220 cm: Kg. 55 \_ m<sup>3</sup>0,23 \_ 1 x box / 3 boxes

240 cm: Kg. 59 \_ m<sup>3</sup>0,24 \_ 1 x box / 3 boxes

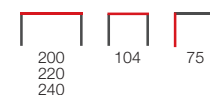

Piano in HPL, forma stondata  
HPL, barrel-shaped top



**Voglia  
di dipingere**

*Feel like  
painting*



 Echo  
vol. / 02 \_ 208

 Casper  
vol. / 02 \_ 196



Sandwich  
o tartare?

Sandwich  
or tartare?

Stone-P  
vol. / 02 \_ 188

Terra-va  
vol. / 02 \_ 236

*Stone-T's design  
is inspired by  
megaliths and thanks  
to the materials used  
and its structural  
lightness, it is perfect  
for long-term use  
outdoors.*

**Il design del tavolo  
Stone-T si ispira  
alle forme  
dei megaliti  
e grazie  
ai materiali  
utilizzati e  
alla leggerezza  
strutturale  
è perfetto per  
un duraturo uso  
esterno.**

## STONE-T

Design \_ Arter & Citton

Patented

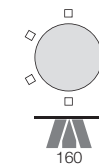

### Packing

Kg. 60 \_ m³0,31 \_ 1 x box / 3 boxes



Piano in HPL  
HPL top



# COMPASS

Design \_ Arter & Citton  
Patented

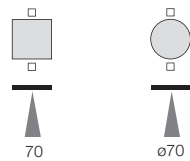
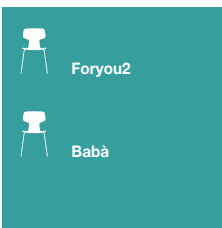

vol. / 02\_206  
vol. / 02\_198



COMPASS-T



COMPASS-Q

**Packing**  
Kg. 18,5 \_ m<sup>2</sup>0,15 \_ 1 x box / 2 boxes (**piano quadrato polietilene** \_ polyethylene square top)  
Kg. 20,3 \_ m<sup>2</sup>0,14 \_ 1 x box / 2 boxes (**piano quadrato laminato** \_ laminate square top)  
Kg. 17,7 \_ m<sup>2</sup>0,15 \_ 1 x box / 2 boxes (**piano tondo polietilene** \_ polyethylene round top)  
Kg. 18,8 \_ m<sup>2</sup>0,14 \_ 1 x box / 2 boxes (**piano tondo laminato** \_ laminate round top)

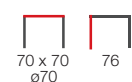

Piano in polietilene o HPL  
Polyethylene or HPL top



Un giro  
attorno  
al mondo  
*One round  
around  
the world*

Foryou  
vol. / 02 \_ 204

Terra-VA  
vol. / 02 \_ 236



## TERRA-T

Design \_ Arter & Citton  
Patented

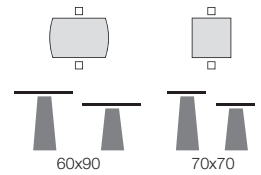

TERRA-TB



TERRA-TA

TERRA-TA

**Packing**

Kg. 18,2 \_ m³0,28 \_ 1 x box / 3 boxes (**piano quadrato** \_ square top)

Kg. 17,4 \_ m³0,28 \_ 1 x box / 3 boxes (**piano stondato** \_ barrel-shaped top)

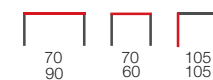

TERRA-TB

**Packing**

Kg. 15,8 \_ m³0,19 \_ 1 x box / 3 boxes (**piano quadrato** \_ square top)

Kg. 15 \_ m³0,19 \_ 1 x box / 3 boxes (**piano stondato** \_ barrel-shaped top)

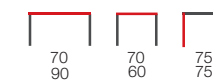

Piano in HPL  
HPL top

# CROWN

Design \_ Domitalia  
Patented

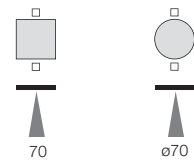

CROWN-A



CROWN-B

CROWN-A

**Packing**  
Kg. 16 \_ m<sup>3</sup>0,24 \_ 1 x box / 3 boxes (**piano quadrato** \_ square top)  
Kg. 14,6 \_ m<sup>3</sup>0,24 \_ 1 x box / 3 boxes (**piano tondo** \_ round top)

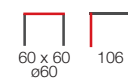

CROWN-B

**Packing**  
Kg. 14,3 \_ m<sup>3</sup>0,18 \_ 1 x box / 3 boxes (**piano quadrato** \_ square top)  
Kg. 12,9 \_ m<sup>3</sup>0,18 \_ 1 x box / 3 boxes (**piano tondo** \_ round top)

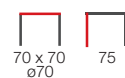

Piano in HPL  
HPL top

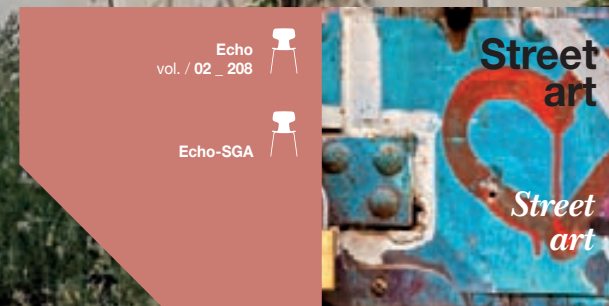

Incontro galante

A gallant meeting



FORYOU  
vol. / 02\_204



## TRIPLE

Design \_ Arter & Citton  
Patented



Echo



Echo-SGA



vol. / 02\_208



**Packing**  
K. 12,8\_m³0,11\_1 x box / 4 boxes (piano quadrato \_ square top)  
Kg. 12\_m³0,12\_1 x box / 4 boxes (piano tondo \_ round top)



60 x 60  
ø70



Piano in HPL  
HPL top



# TERRA-V

Design \_ Arter & Citton

Patented



TERRA-VB

TERRA-VA

Kg. 1,3 \_ m³0,01 \_ 1 x box (**Kit con filo** \_ Kit with cord)  
 Kg. 1,5 \_ m³0,01 \_ 1 x box (**Kit con filo e lampadina led** \_ Kit with cord and led bulb)  
 Kg. 3 \_ m³0,01 \_ 1 x box (**Kit senzafilo** \_ Kit without cord)

TERRA-VA  
**Packing**  
 Kg. 10,9 \_ m³0,25 \_ 1 x box

TERRA-VB  
**Packing**  
 Kg. 8 \_ m³0,15 \_ 1 x box

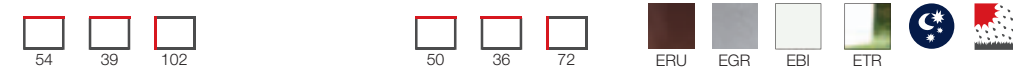

**Optional kit di drenaggio**  
 Optional drain kit







# OMNIA

Design \_ Radice & Orlandini  
Patented



Kg. 1,3 \_ m² 0,01 \_ 1 x box (**Kit con filo** \_ Kit with cord)  
Kg. 1,5 \_ m² 0,01 \_ 1 x box (**Kit con filo e lampadina led** \_ Kit with cord and led bulb)  
Kg. 3 \_ m² 0,01 \_ 1 x box (**Kit senzafilo** \_ Kit without cord)

**Packing**  
Kg. 4,2 \_ m² 0,11 \_ 1 x box (**vaso** \_ pot)  
Kg. 1,5 \_ m² 0,03 \_ 1 x box (**cuscinio** \_ cushion)  
Kg. 2,5 \_ m² 0,006 \_ 1 x box (**piano vetro** \_ glass top)  
Kg. 1,5 \_ m² 0,006 \_ 1 x box (**piano laminato** \_ laminate top)

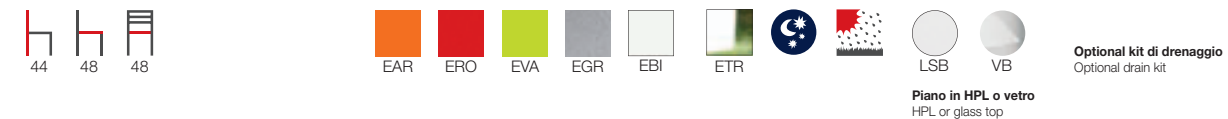

Piano in HPL o vetro  
HPL or glass top



**FINITURE**

*Finishes  
Ausführungen  
Finitions  
Acabados*

# FINITURE *finishes*

## LEGNI VERNICIATI

Varnished woods \_ Holz gebeizt \_ Bois vernis \_ Maderas acabadas

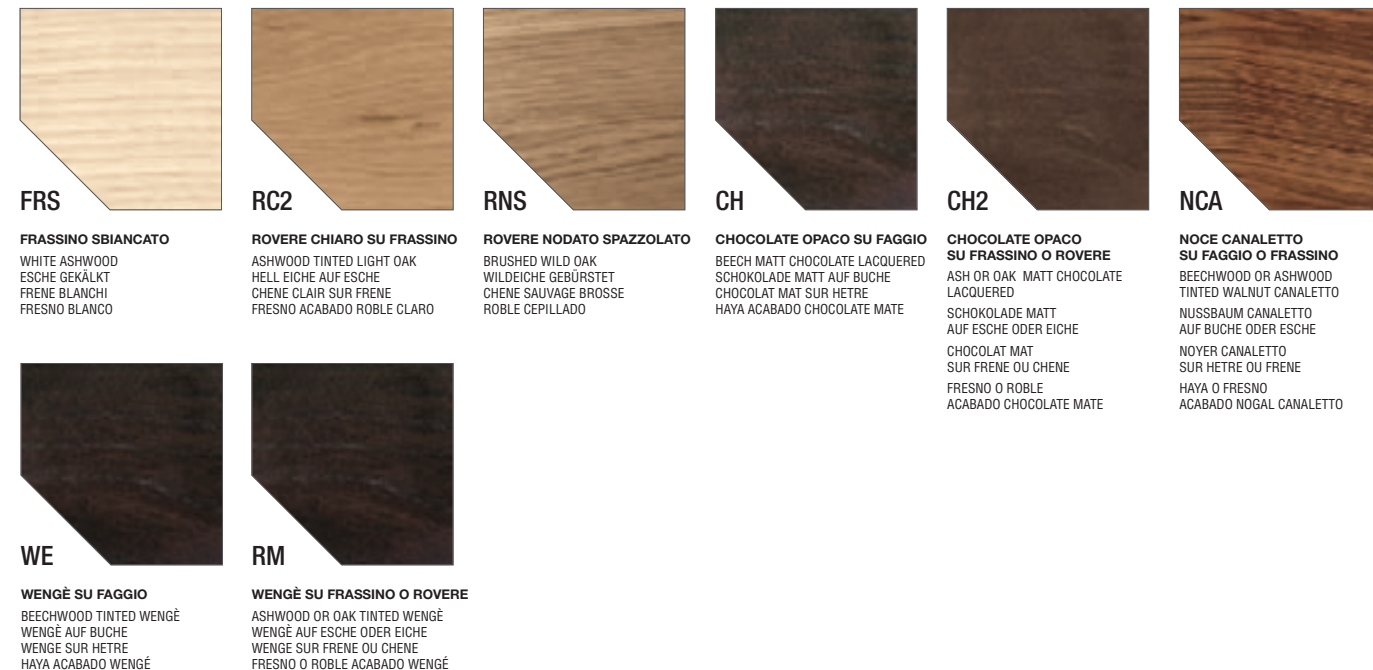

## LEGNI LACCATI

Lacquered woods \_ Holz lackiert \_ Bois laqués \_ Maderas lacadas

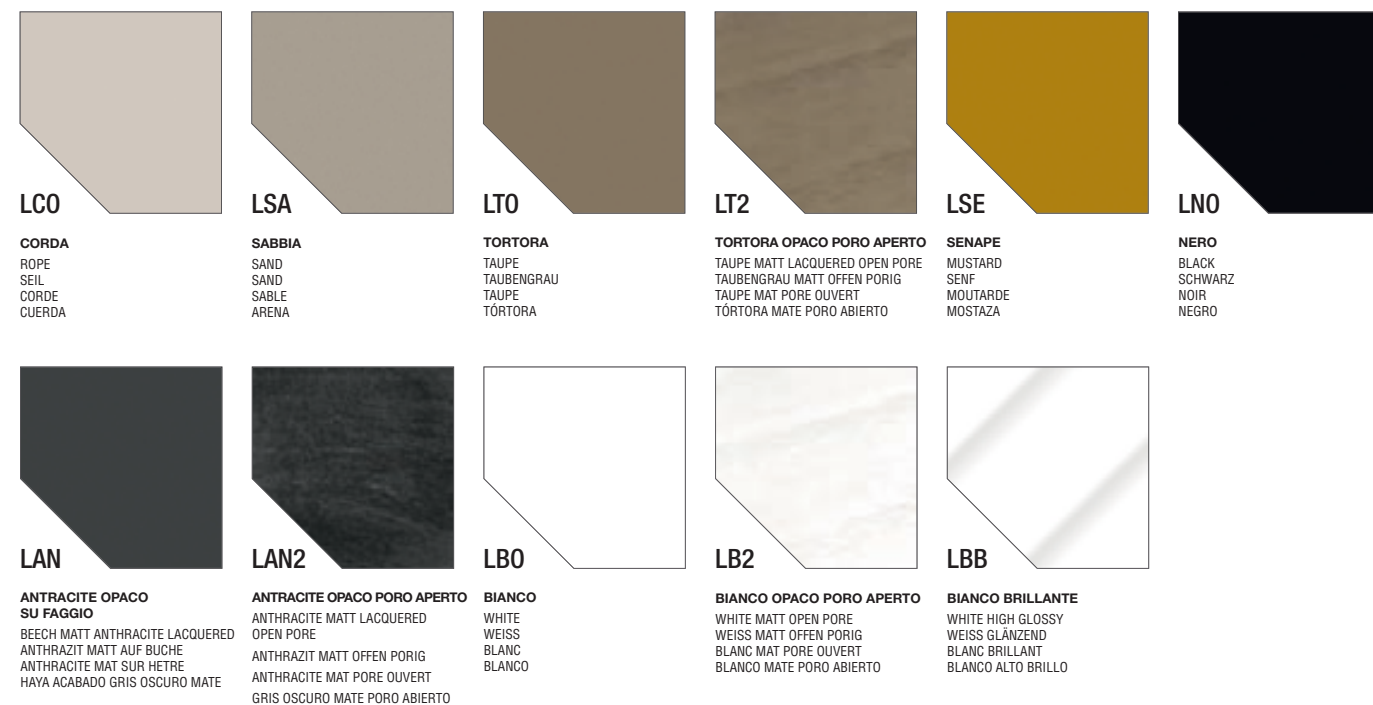

# FINITURE *finishes*

## MELAMINICI

Melamine \_ Melamin \_ Melamine \_ Melaminado

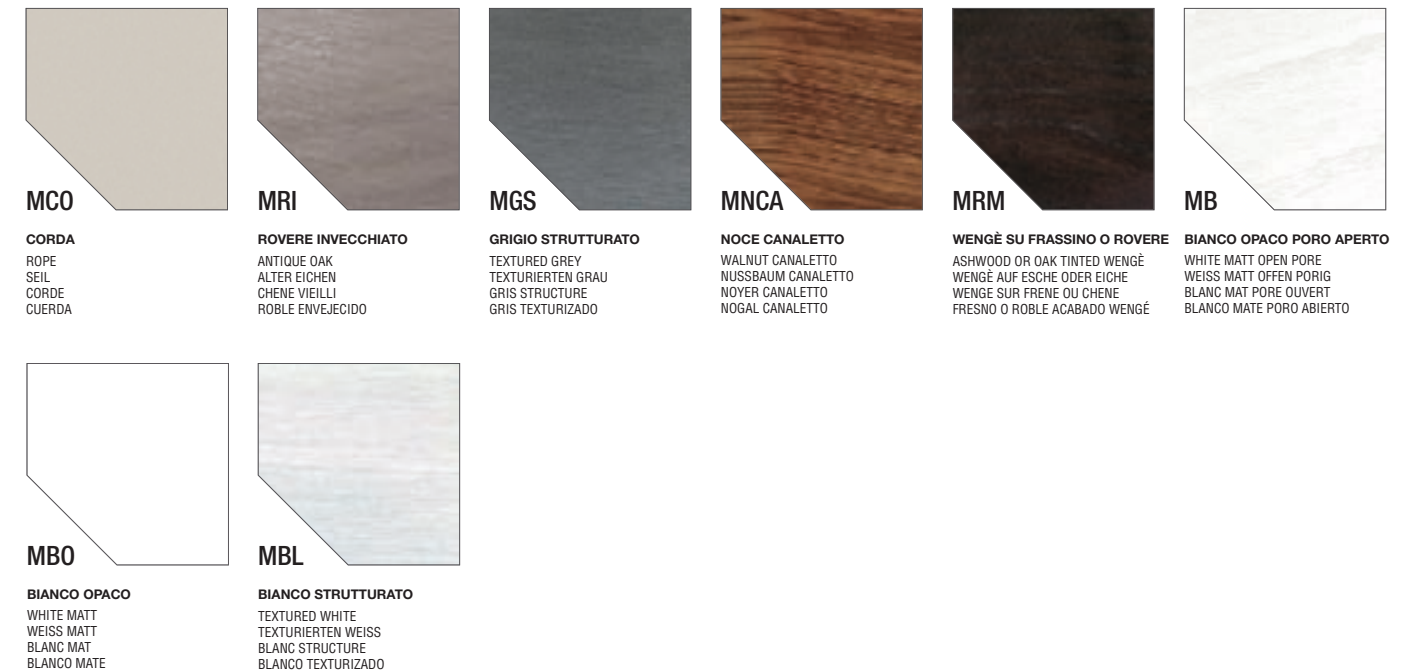

## LAMINATO

Laminate \_ Laminat \_ Stratifié \_ Laminado

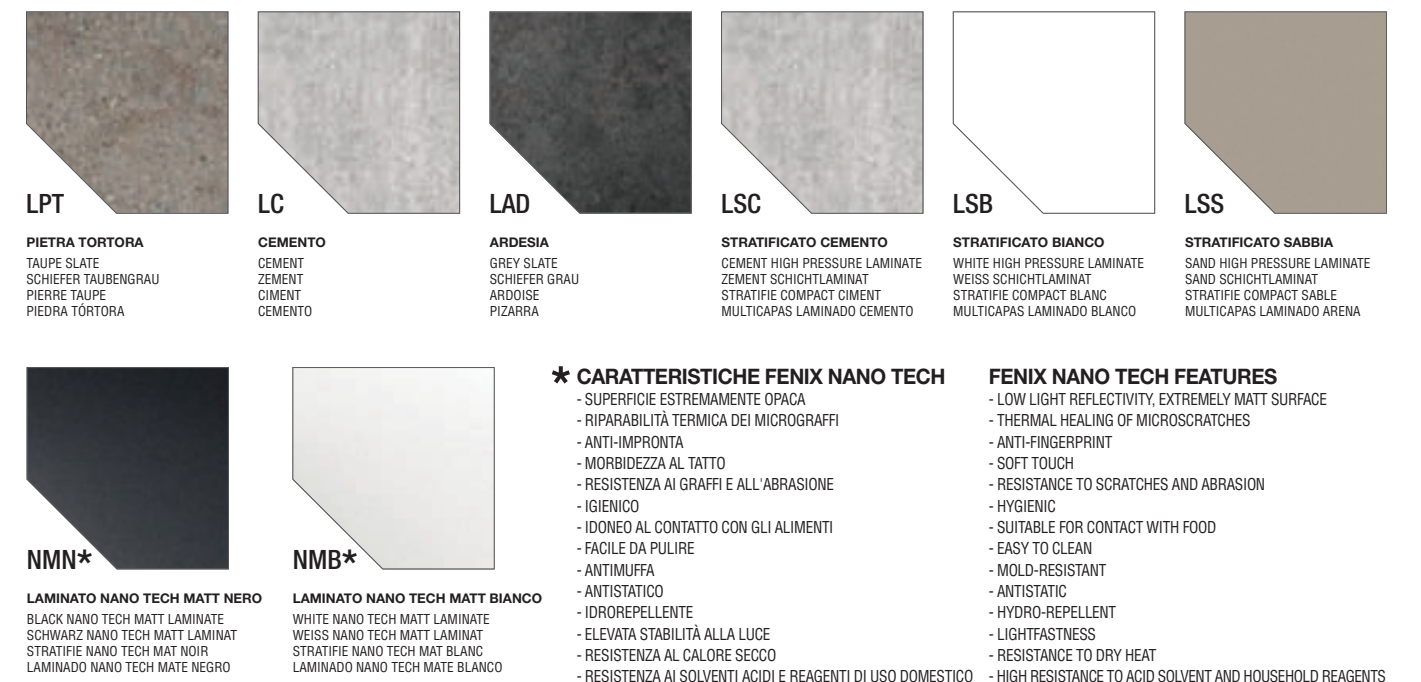



# FINITURE *finishes*

## ACCIAIO

Steel \_ Stahl \_ Acier \_ Acero

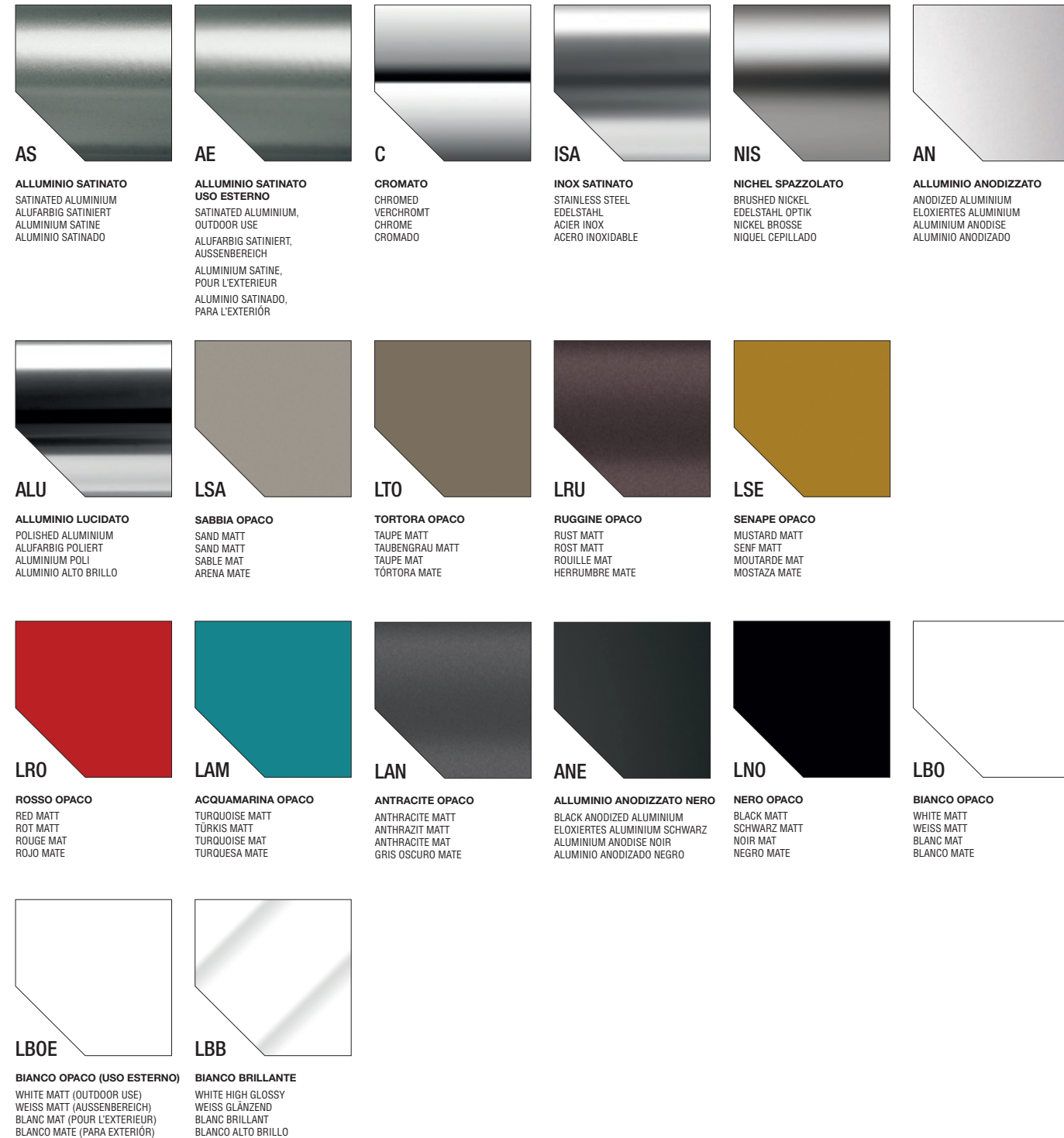

# FINITURE *finishes*

## VETRO TEMPRATO

Tempered glass \_ Sicherheitglas \_ Verre trempé \_ Vidrio templado

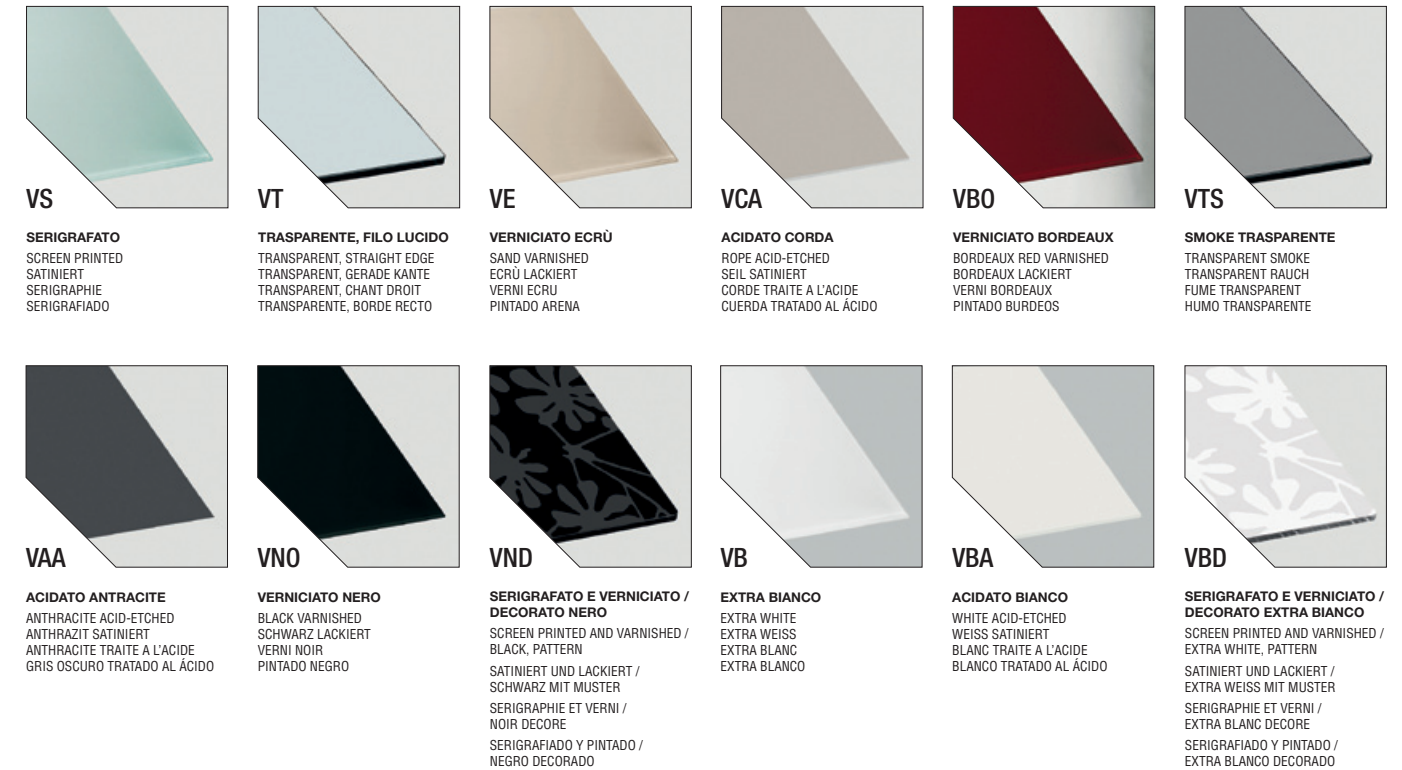

## CERAMICA (su supporto in vetro o MDF)

Ceramic (on glass or MDF support) \_ Keramikglas (auf Glas oder MDF)  
Céramique (sur support verre ou MDF) \_ Cerámica (sobre vidrio o MDF)



# FINITURE *finishes*

## POLIURETANO

*Polyurethane \_ Polyurethan \_ Polyuréthane \_ Poliuretano*

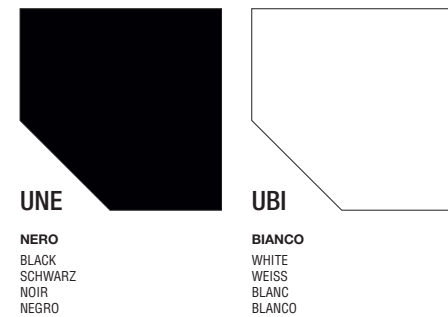
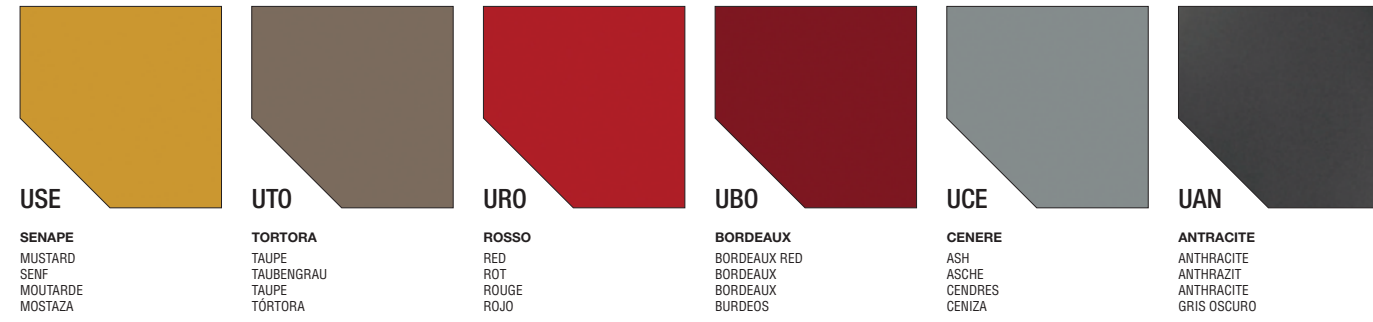

## POLIPROPILENE

*Polypropylene \_ Polypropylen \_ Polypropylène \_ Polipropileno*

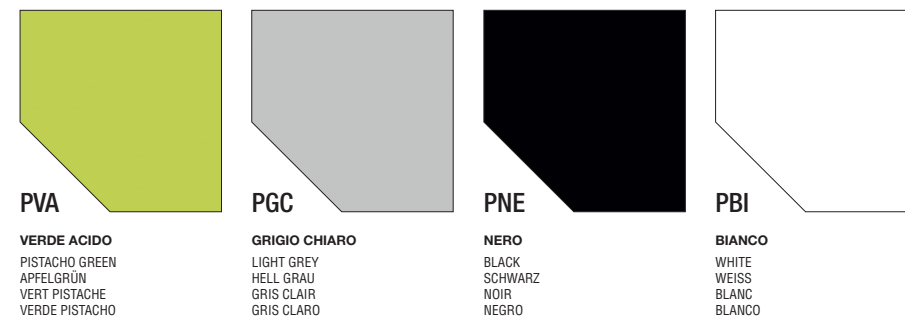
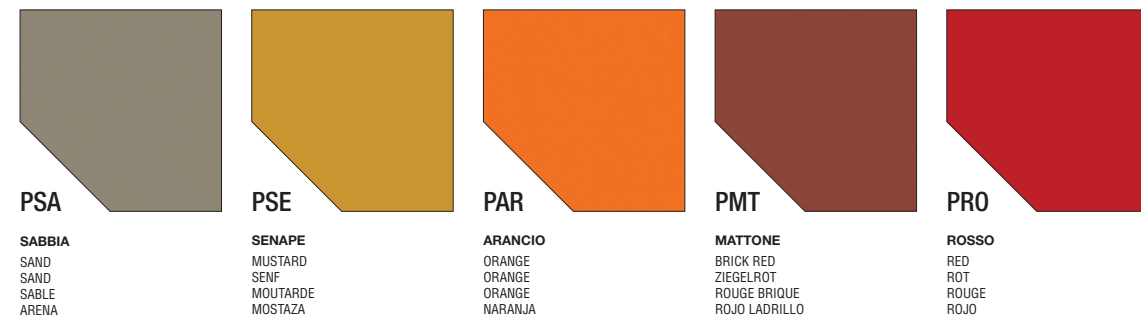

# FINITURE *finishes*

## POLICARBONATO

*Polycarbonate \_ Polycarbonat \_ Polycarbonate \_ Policarbonado*

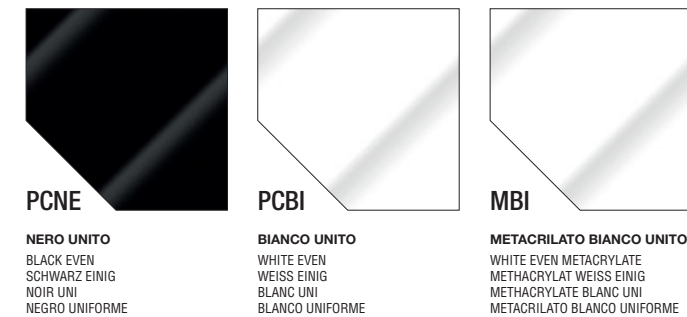
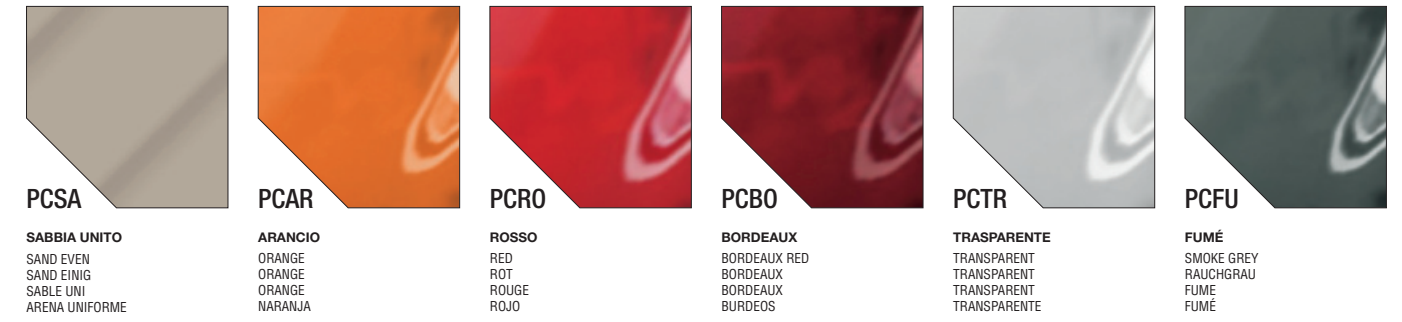

## STIRENE ACRILO NITRILE

*Styrene acryl nitril \_ Styrol Acrylnitril \_ Styrene acrole nitrile \_ Stirene de nitril acrilico*

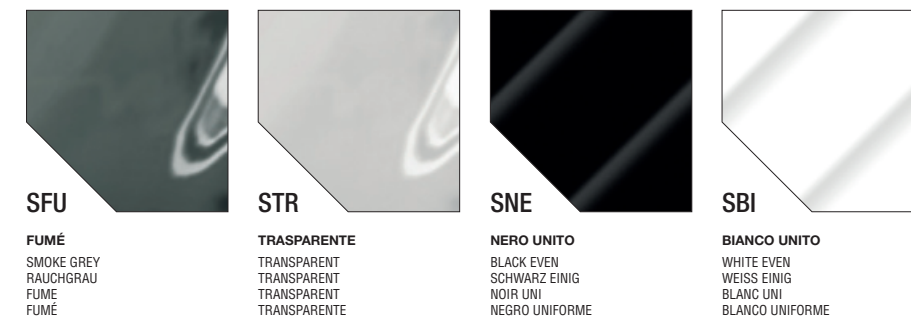

# FINITURE *finishes*

## POLIETILENE

*Polyethylene \_ Polyethylen \_ Polyéthylène \_ Polietileno*



## SUGHERO NATURALE

*Natural cork \_ Naturkorken \_ Liège naturel \_ Corcho natural*

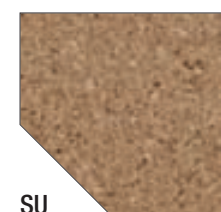

**LA SEDUTA IN SUGHERO PUÒ ESSERE PERSONALIZZATA CON UN LOGO A STAMPA LASER DI CUI IL CLIENTE FORNIRÀ UN FILE IN FORMATO VETTORIALE.**  
THE CORK SEAT CAN BE PERSONALIZED WITH A LASER PRINTING LOGO AND THE CUSTOMER MUST SUPPLY A FILE IN VECTOR FORMAT.  
DER SITZ AUS KORKEN KANN MIT EINEM LOGO IN LASERDRUCK PERSONALISIERT WERDEN UND DER KUNDE SOLL EINE DATEI IN VEKTOR-FORMAT SCHICKEN.  
L'ASSISE EN LIEGE PEUT ETRE PERSONNALISEE AVEC UN LOGO EN IMPRESSION LASER ET LE CLIENT DEVRA FOURNIR UN FICHIER DANS UN FORMAT VECTORIEL.  
EL ASIENTO EN CORCHO SE PUEDE PERSONALIZAR CON UN LOGOTIPO EN LA IMPRESIÓN LÁSER Y EL CLIENTE TIENE QUE PROVEDER A ENVIAR UN FILE EN FORMATO VECTORIAL.

**SU**

## RETE

*Net \_ Netz \_ Filet \_ Red*

**COMPOSIZIONE**  
COMPOSITION:  
30% PL, 70% PVC

**SOLIDITÀ ALLA LUCE**  
LIGHT FASTNESS:  
> 7

**RESISTENZA ALL'ABRASIONE**  
ABRASION RESISTANCE:  
MARTINDALE  
≥ 100.000 CICLI / CYCLES

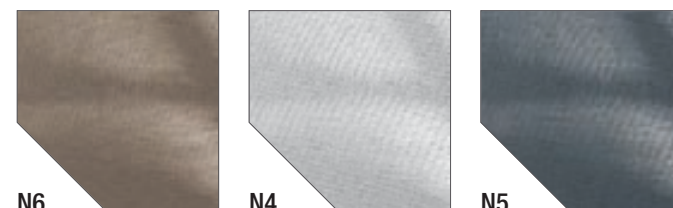

**N6**

**TORTORA**  
TAUPE  
TAUBENGRAU  
TAUPE  
TÓRTORA

**N4**

**GRIGIO CHIARO**  
LIGHT GREY  
HELL GRAU  
GRIS CLAIR  
GRIS CLARO

**N5**

**GRIGIO SCURO**  
DARK GREY  
DUNKEL GRAU  
GRIS FONCE  
GRIS OSCURO

## CEMENTO

*Cement \_ Zement \_ Ciment \_ Cemento*

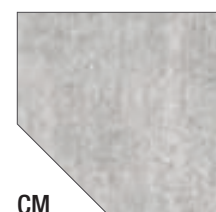

**CM**

**CEMENTO**  
CEMENT  
ZEMENT  
CIMENT  
CEMENTO

# FINITURE *finishes*

## PELLE RIGENERATA

*Regenerated leather \_ Regeneriertes leder \_ Synderme \_ Piel reconstruida*

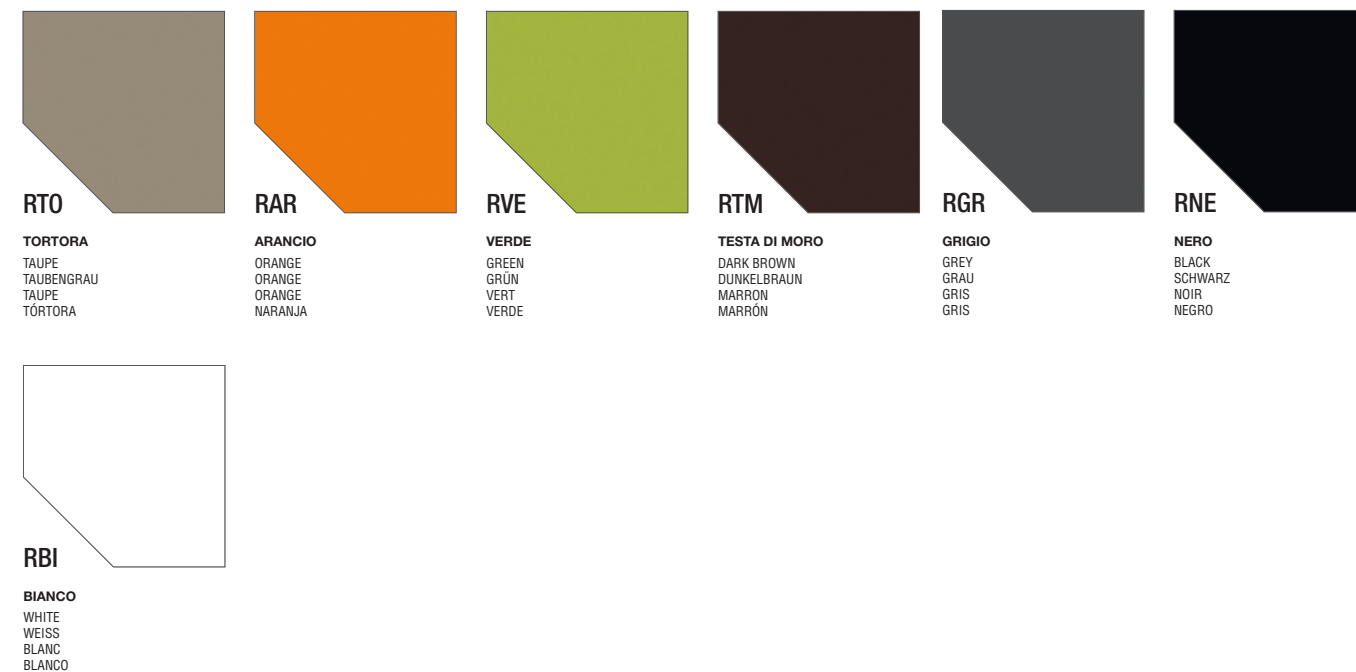

## PELLE CROSTA E SMERIGLIATA

*2<sup>nd</sup> quality and grain leather \_ Crostaleder und Leder \_ Croûte de cuir et cuir grené \_ Piel 2<sup>a</sup> calidad y esmerilada*

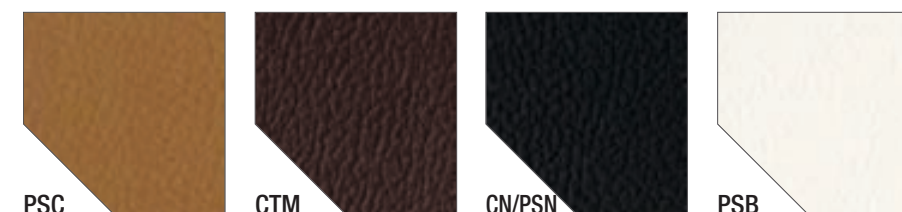

**PSC**

**CUOIO**  
TOBACCO  
TABAK  
TABAC  
TABACO

**CTM**

**TESTA DI MORO**  
DARK BROWN  
DUNKELBRAUN  
MARRON  
MARRÓN

**CN/PSN**

**NERO**  
BLACK  
SCHWARZ  
NOIR  
NEGRO

**PSB**

**BIANCO**  
WHITE  
WEISS  
BLANC  
BLANCO

# FINITURE

*finishes*

**TESSUTO**  
Fabric \_ Stoff \_ Tissu \_ Tejido

## 8290

**COMPOSIZIONE**  
COMPOSITION:  
100% PL

**SOLIDITÀ ALLA LUCE**  
LIGHT FASTNESS:  
≥ 4

**RESISTENZA ALL'ABRASIONE**  
ABRASION RESISTANCE:  
MARTINDALE  
≥ 30.000 CICLI / CYCLES



**8-06**

**NERO**  
BLACK  
SCHWARZ  
NOIR  
NEGRO

## LONGLIFE

**COMPOSIZIONE**  
COMPOSITION:  
74% PL, 18% CO, 8% PC

**SOLIDITÀ ALLA LUCE**  
LIGHT FASTNESS:  
4

**RESISTENZA ALL'ABRASIONE**  
ABRASION RESISTANCE:  
MARTINDALE  
≥ 40.000 CICLI / CYCLES



**L604**

**FANGO**  
MUD  
SCHLAMMFARBE  
BOUE  
BARRO

**L600**

**GRIGIO CHIARO**  
LIGHT GREY  
HELL GRAU  
GRIS CLAIR  
GRIS CLARO

**L601**

**GRIGIO SCURO**  
DARK GREY  
DUNKEL GRAU  
GRIS FONCE  
GRIS OSCURO



## NORDWOOL

**COMPOSIZIONE**  
COMPOSITION:  
70% WO, 25% PA, 5% AF

**SOLIDITÀ ALLA LUCE**  
LIGHT FASTNESS:  
5

**RESISTENZA ALL'ABRASIONE**  
ABRASION RESISTANCE:  
MARTINDALE  
≥ 100.000 CICLI / CYCLES



**NW502**

**SENAPE**  
MUSTARD  
SENF  
MOUTARDE  
MOSTAZA

**NW802**

**VERDE OLIVA**  
OLIVE GREEN  
OLIVGRÜN  
VERT OLIVE  
VERDE ACEITUNA

**NW600**

**GRIGIO CHIARO**  
LIGHT GREY  
HELL GRAU  
GRIS CLAIR  
GRIS CLARO

**NW200**

**GRIGIO SCURO**  
DARK GREY  
DUNKEL GRAU  
GRIS FONCE  
GRIS OSCURO

## FLIRT

**COMPOSIZIONE**  
COMPOSITION:  
100% PL

**SOLIDITÀ ALLA LUCE**  
LIGHT FASTNESS:  
≥ 3/4

**RESISTENZA ALL'ABRASIONE**  
ABRASION RESISTANCE:  
MARTINDALE  
≥ 30.000 CICLI / CYCLES



**F600**

**SABBIA**  
SAND  
SAND  
SABLE  
ARENA

**F804**

**SENAPE**  
MUSTARD  
SENF  
MOUTARDE  
MOSTAZA

**F707**

**JEANS**  
JEANS  
JEANS  
JEANS  
JEANS

**F602**

**MARRONE**  
BROWN  
BRAUN  
MARRON  
MARRÓN



# FINITURE

*finishes*

**ECOPELLE**  
Imitation leather \_ Kunstleder \_ Similicuir \_ Imitación Piel

## YUTA

**COMPOSIZIONE**  
COMPOSITION:  
98% PVC, 2% PU

**SOLIDITÀ ALLA LUCE**  
LIGHT FASTNESS:  
5

**RESISTENZA ALL'ABRASIONE**  
ABRASION RESISTANCE:  
MARTINDALE  
≥ 50.000 CICLI / CYCLES



**YU3**

**TORTORA**  
TAUPE  
TAUBENGRAU  
TAUPE  
TÓRTORA

**YU2**

**NERO**  
BLACK  
SCHWARZ  
NOIR  
NEGRO

**YU1**

**BIANCO**  
WHITE  
WEISS  
BLANC  
BLANCO

## PUMA

**COMPOSIZIONE**  
COMPOSITION:  
100% PL

**SOLIDITÀ ALLA LUCE**  
LIGHT FASTNESS:  
5

**RESISTENZA ALL'ABRASIONE**  
ABRASION RESISTANCE:  
MARTINDALE  
≥ 40.000 CICLI / CYCLES



**P555**

**GRIGIO**  
GREY  
GRAU  
GRIS  
GRIS

**P501**

**NERO**  
BLACK  
SCHWARZ  
NOIR  
NEGRO

**P559**

**BIANCO**  
WHITE  
WEISS  
BLANC  
BLANCO

## BLOOM

**COMPOSIZIONE**  
COMPOSITION:  
15% PL, 85% PVC

**SOLIDITÀ ALLA LUCE**  
LIGHT FASTNESS:  
4/5

**RESISTENZA ALL'ABRASIONE**  
ABRASION RESISTANCE:  
MARTINDALE  
≥ 50.000 CICLI / CYCLES



**B9**

**BEIGE**  
BEIGE  
BEIGE  
BEIGE  
BEIGE

**B14**

**TORTORA**  
TAUPE  
TAUBENGRAU  
TAUPE  
TÓRTORA

**B7**

**GRIGIO**  
GREY  
GRAU  
GRIS  
GRIS

**B8**

**NERO**  
BLACK  
SCHWARZ  
NOIR  
NEGRO

**B1**

**BIANCO**  
WHITE  
WEISS  
BLANC  
BLANCO

L'ECOPELLE, PUR DELLA MIGLIORE QUALITÀ, È UN MATERIALE POROSO CHE, A CONTATTO CON TESSUTI O ELEMENTI CHE STINGONO E A UNA SUDORAZIONE ACIDA, ASSORBE LA COLORAZIONE IN MANIERA IRREPARABILE, SOPRATTUTTO NELLE TONALITÀ PIÙ CHIARE.

THE IMITATION LEATHER, EVEN OF BEST QUALITY, HAS AN OPEN GRAIN AND WHEN TOUCHING EASILY FADING MATERIALS AND FABRICS OR ACID PERSPIRATION, IT ABSORBS COLOURS IRREPARABLY, ESPECIALLY ON LIGHT SHADES.

DAS KUNSTLEDER, OBWOHL AUS BESTE QUALITÄT, IST EIN PÖROSES MATERIAL, DAS NEBEN BEZÜGEN, WELCHE DIE FARBE VERLIEREN, ODER IM FALL VON SCHWITZENSÄURE, DIE FÄRBUNG BESONDERS AUF KUNSTLEDER WEISS UND BEIGE UNERSATZBAR AUFNIMMT.

LE SIMILICUIR, MÊME SI DE LA MEILLEURE QUALITÉ, EST UN MATÉRIEL POREUX, QUI, À CONTACT AVEC DES TISSUS OU DES MATÉRIAUX QUI DÉTEIGNENT FACILEMENT, OU AVEC UNE TRANSPIRATION ACIDE, ABSORBE LA COULEUR DE FAÇON IRREPARABLE, SURTOUT DANS LES TEINTES CLAIRES.

LA IMITACIÓN PIEL ES UN MATERIAL POROSO Y, AUNQUE DE LA MEJOR CALIDAD, SI EN CONTACTO CON TEJIDOS QUE DESCOLORON Y CON UNA TRASPIRACIÓN ÁCIDA, ABSORBE LA COLORACIÓN EN MANERA IRREPARABLE, ESPECIALMENTE EN LAS VERSIONES BLANCO Y BEIGE.

SI RACCOMANDA UN'ATTENZIONE ED UNA CURA PARTICOLARE PER LE SEDIE CON LE GAMBE RIVESTITE IN ECOPELLE, IN QUANTO SONO SOGGETTE PIU' DI ALTRE A SPORCARSÌ E GRAFFIARSI SE UTILIZZATE IN MODO NON APPROPRIATO.

WE RECOMMEND A SPECIAL ATTENTION AND CARE FOR THE CHAIRS WITH THE LEGS COVERED WITH IMITATION LEATHER. THEY ARE PARTICULARLY SUBJECT, IF NOT PROPERLY USED, TO DIRT AND SCRATCHES.

FÜR DIE BEINE DER STÜHLEN MIT KUNSTLEDER ÜBERZOGEN, EMPFEHLEN WIR EINE BESONDERE AUFMERKSAMKEIT UND EINE SPEZIELLE BEHANDLUNG, DA DIESE STÜHLE AUF GRUND EINER UNKORREKTE BENUTZUNG EMPFINDLICHER MEHR ALS ANDERE GEGEN SCHMUTZIGKEIT UND KRATZEN SIND.

UNE ATTENTION ET UN SOIN PARTICULIER SONT RECOMMANDÉS POUR LES CHAISES DONT LES PIEDS SONT RECOUVERTS DE SIMILICUIR, ETANT DONNE QU'ELLES SE SALISSENT ET SE GRIFFENT PLUS FACILEMENT QUE D'AUTRES SI ON LES UTILISE D'UNE FAÇON INAPPROPRIÉE.

PARA SILLAS CON PATAS REVESTIDAS EN SIMILPIEL SE RECOMIENDA QUE ATENCIÓN Y CUIDADOS ESPECIALES COMO ESTÁN MÁS SUJETAS A SUCIARSE Y RAYARSE SI USADAS EN MANERA NO APROPIADA.





PER LA PULIZIA DI QUALSIASI PRODOTTO RACCOMANDIAMO DI UTILIZZARE UN DETERGENTE NEUTRO CON UN PANNO MORBIDO INUMIDITO CON ACQUA TIEPIDA. EVITARE L'USO DI SOLVENTI O SOSTANZE ACIDE E ABRASIVE.

WE RECOMMEND TO CLEAN ANY PRODUCT WITH A NEUTRAL DETERGENT AND DAMP CLOTH. AVOID USING ACID SUBSTANCES, SOLVENTS OR ABRASIVE PRODUCTS.

ZUR REINIGUNG UNSERER ARTIKEL EMPFEHLEN WIR IHNEN, EIN MILDES REINIGUNGSMITTEL UND EINEN MIT LAUWARMEM WASSER BEFEUCHTETEN LAPPEN ZU VERWENDEN. ÄTZENDE SUBSTANZEN, LÖSUNGSMITTEL, HEISSE FLÜSSIGKEITEN ODER AUFSCHUEERENDE MITTEL SIND ZU VERMEIDEN.

POUR LE NETTOYAGE DE N'IMPORTE QUEL PRODUIT NOUS RECOMMANDONS D'UTILISER UN DÉTERGENT NEUTRE AVEC UN CHIFFON MOELLEUX HUMIDIFIÉ AVEC DE L'EAU TIÈDE. ÉVITER L'USAGE DE SUBSTANCES ACIDES, DE SOLVANTS OU DE MATÉRIELS ABRASIFS.

PARA LA LIMPIEZA DE CADA PRODUCTO SE RECOMIENDA UTILIZAR UN DETERGENTE NEUTRO CON UN PAÑO HUMEDUSITO CON AGUA TIBIA. EVITAR SOLVENTES O SUSTANCIAS ÁCIDAS Y ABRASIVAS.

LE FINITURE E I RIVESTIMENTI DEI PRODOTTI SONO PURAMENTE INDICATIVI PER LE INEVITABILI DIFFERENZE DOVUTE ALLA RIPRODUZIONE FOTOGRAFICA E NON POSSONO ESSERE FATTI OGGETTO DI COMPARAZIONE CON IL PRODOTTO FINALE. DOMITALIA SI RISERVA IL DIRITTO DI MODIFICARE PARZIALMENTE O TOTALMENTE LA PROPRIA PRODUZIONE SENZA ALCUN PREAVVISO E IN QUALSIASI MOMENTO E DI APPORTARE MIGLIORIE E VARIANTI A SUO INSINDACABILE GIUDIZIO. PERTANTO NON VI È OBBLIGO ALCUNO DI RISPETTO DELLE FINITURE O CARATTERISTICHE PER SUCCESSIVE FORNITURE. INVITIAMO A CONSULTARE IL LISTINO ALLEGATO PER DETTAGLI ED APPROFONDIMENTI PRECISI RELATIVAMENTE AGLI ARTICOLI INSERITI NEL CATALOGO.

THE FINISHES AND THE COVERINGS OF THE PRODUCTS ARE PURELY INDICATIVE DUE TO THE DIFFERENCES THAT INEVITABLY APPEAR IN THE PHOTOGRAPHIC REPRODUCTIONS AND THUS CANNOT BE USED AS A COMPARISON WITH THE FINAL PRODUCT. DOMITALIA RESERVES THE RIGHT TO PARTIALLY OR FULLY MODIFY ITS PRODUCTION AT ANY TIME WITHOUT NOTIFICATION AND RESERVES THE RIGHT TO MAKE IMPROVEMENTS OR VARIATIONS THERE TO ENTIRELY AT ITS OWN DISCRETION. THEREFORE, THE COMPANY IS NOT OBLIGED TO RESPECT FINISHES AND CHARACTERISTICS FOR THE COMING SUPPLIES. PLEASE REFER TO THE PRICE-LIST FOR ADDITIONAL INFORMATION ON THE MODELS SHOWN IN THIS CATALOGUE.

DIE ENDVERARBEITUNGEN UND BEZÜGE DER ARTIKEL SIND AUFGRUND DER UNVERMEIDBAREN UNTERSCHIEDE DER FOTOGRAFISCHEN ABBILDUNG REIN BEZEICHNEND UND KÖNNEN FOLGLICH NICHT ALS VERGLEICHSGEGENSTAND ZUM FERTIGPRODUKT GENOMMEN WERDEN. DOMITALIA BEHÄLT SICH DAS RECHT VOR DIE EIGENE PRODUKTION, OHNE JEGLICHE VORWARNUNG UND JEDERZEIT, TEILWEISE ODER GÄNZLICH ABZUÄNDERN UND NACH EIGENEM GUTDÜNKEN VERBESSERUNGEN ODER VARIANTEN VORZUNEHMEN. ES BESTEHT DAHER KEINE PFLICHT DIE ENDVERARBEITUNGEN ODER MERKMALE AUCH BEI DEN FOLGENDEN LIEFERUNGEN BEIZUBEHALTEN. GENAUERE EINZELHEITEN ODER ERKLÄRUNGEN ZU DEN ARTIKELN UNSERES KATALOGS FINDEN SIE IN UNSERER BEIGELEGTEN PREISLISTE.

LES FINITIONS ET LES REVÊTEMENTS DES PRODUITS ONT UN CARACTÈRE PUREMENT INDICATIF À CAUSE DES INÉVITABLES DIFFÉRENCES DUES À LA REPRODUCTION PHOTOGRAPHIQUE ET, PAR CONSÉQUENT, ILS NE PEUVENT PAS ÊTRE COMPARÉS AU PRODUIT FINAL. À TOUT MOMENT ET SANS AVIS PRÉALABLE, DOMITALIA SE RÉSERVE LE DROIT DE MODIFIER PARTIELLEMENT OU INTÉGRALEMENT SA PRODUCTION ET, DE MÊME, D'APPORTER DES AMÉLIORATIONS ET DES MODIFICATIONS À SA DISCRETION. PAR CONSÉQUENT, DOMITALIA N'EST PAS TENUE D'UTILISER LES MÊMES FINITIONS OU DE MAINTENIR LES MÊMES CARACTÉRISTIQUES LORS DES FOURNITURES SUCCESSIVES. NOUS INVITONS NOTRE CLIENTÈLE À CONSULTER LE TARIF CI-JOINT POUR TOUT DÉTAIL ET INFORMATION SPÉCIFIQUE CONCERNANT LES ARTICLES PRÉSENTÉS DANS LE CATALOGUE.

LOS ACABADOS Y REVESTIMIENTOS DE LOS PRODUCTOS SON A TÍTULO PURAMENTE INDICATIVO, POR LAS INEVITABLES DIFERENCIAS DEBIDAS A LA REPRODUCCIÓN FOTOGRAFICA Y, POR ENDE, NO PUEDEN SER OBJETO DE COMPARACIÓN CON EL PRODUCTO FINAL. DOMITALIA SE RESERVA EL DERECHO DE MODIFICAR, PARCIAL O TOTALMENTE, SU PROPIA PRODUCCIÓN EN CUALQUIER MOMENTO Y SIN NINGÚN AVISO PREVIO, ASÍ COMO DE APORTAR MEJORIAS Y VARIANTES A SU INCUESTIONABLE JUICIO. POR LO TANTO, NO HAY OBLIGACIÓN ALGUNA DE RESPETAR ACABADOS O CARACTERÍSTICAS PARA FUTUROS SUMINISTROS. PARA DETALLES Y MAYORES ACLARACIONES CON RESPECTO A LOS ARTÍCULOS DEL CATÁLOGO, CONSULTAR EL LISTÍN ANEXO.

È VIETATA LA RIPRODUZIONE, ANCHE PARZIALE, DI TUTTE LE IMMAGINI INSERITE NEL PRESENTE CATALOGO. LE STESSE POTRANNO ESSERE UTILIZZATE UNICAMENTE PREVIA AUTORIZZAZIONE SCRITTA DA PARTE DELLA DOMITALIA SPA.

IT IS FORBIDDEN TO REPRODUCE ENTIRELY OR PARTIALLY ANY IMAGE IN THIS CATALOGUE. THEY MAY BE USED ONLY AFTER WRITTEN AUTHORIZATION OF DOMITALIA SPA.

AUCH EINE TEILWEISE REPRODUKTION ALLER IM VORLIEGENDEN KATALOG ENTHALTENEN BILDER IST VERBOTEN. DIESE DÜRFEN NUR NACH VORHERIGER SCHRIFTLICHER GENEHMIGUNG DURCH DOMITALIA SPA.

LA REPRODUCTION DE N'IMPORTE QUELLE IMAGE MÊME SI PARTIELLE, INSÉRÉE DANS CE CATALOGUE EST INTERDITE. CES IMAGES POURRONT ÊTRE UTILISÉES UNIQUEMENT APRÈS AVOIR OBTENU UNE AUTORISATION ÉCRITE PAR DOMITALIA SPA.

ESTÁ PROHIBIDA LA REPRODUCCIÓN INCLUSO PARCIAL, DE LAS IMÁGENES PRESENTES EN ESTE CATÁLOGO. LAS MISMAS SE PADRÁN UTILIZAR ÚNICAMENTE PREVIA AUTORIZACIÓN ESCRITA POR PARTE DE DOMITALIA SPA.

FOTOGRAFIE  
Silvio Salvador

FOTOLITI  
Color separation Lemon

PROGETTO GRAFICO  
E IMPAGINAZIONE  
www.dsegno.biz

COPY  
Daniele Varelli

STAMPA  
Sincromia / Printed in Italy